

VA-1W Series

1W Unregulated Single output

Features

- 4 Pin SIL / 8 Pin DIL Package
- 1000 VDC Isolation
- Up to 3000 VDC Isolation
- Low Ripple and Noise
- Efficiency up to 83%
- -40 ~ 85°C Operation Temperature Range
- Non-Conductive Black Plastic Case
- EMI Complies With EN55032 Class B



The VA series is a family of cost effective 1W single output DC-DC converters. These converters achieve low cost and ultra-miniature SIP 4 pin or DIP 8 pin size. Devices are encapsulated using flame retardant resin. The models operate from input voltage of 3.3, 5, 12, 15, 24 Vdc with output voltage of 3.3, 5, 7.2, 9, 12, 15, 18, 24 Vdc. High performance features include 1000Vdc~3000Vdc input/output isolation, high efficiency operation and output voltage accuracy of $\pm 3\%$ maximum. Standard features include an input range of $\pm 10\%$ tolerance and low output noise and ripple.

All specifications typical at $T_a=25^\circ\text{C}$, nominal input voltage and full load unless otherwise specified

OUTPUT SPECIFICATIONS	
output Voltage accuracy	$\pm 3\%$, max.
Line regulation	$\pm 1.2\%$ / Per 1% Vin Change, max.
Load regulation	(From 20% to 100% Load) $\pm 10\%$, max. (Output 3.3V Model) $\pm 20\%$, max.
Ripple & noise (20 MHz bandwidth)(1)	100mVpk-pk, max.
Temperature coefficient	$\pm 0.02\%/^\circ\text{C}$
Capacitor load(2)	See table, max.

INPUT SPECIFICATIONS	
Input Voltage Range	$\pm 10\%$
Input Current (Full Load)	See table
Input Current (No Load)	See table
Input Filter	Capacitors
Input Reflected Ripple Current(3)	20mA _{pk-pk}

ENVIRONMENT SPECIFICATIONS	
Operating Temperature	$-40^\circ\text{C} \sim 85^\circ\text{C}$
Maximum Case Temperature	100°C
Storage Temperature	$-40^\circ\text{C} \sim 125^\circ\text{C}$
Cooling	Nature Convection

GENERAL SPECIFICATIONS	
Efficiency	See table
I/O Isolation Voltage(60sec)	1000~3000Vdc
Input/Output	1000~3000Vdc
I/O Isolation Capacitance	60 pF Typ.
I/O Isolation Resistance	1000M Ω , max.
Switching Frequency	Variable 80kHz, typ.
Humidity	95% rel H
Reliability Calculated MTBF (MIL-HDBK-217 F)	>1.121Mhrs
Safety Standard : (designed to meet)	IEC/EN 60950-1, 62368-1 UL/cUL 60950-1, 62368-1

PHYSICAL SPECIFICATIONS	
Case Material	Non-conductive Black Plastic(UL94V-0 rated)
Pin Material	SIP Case 0.5mm Alloy42 Solder-coated DIP Case $\Phi 0.5\text{mm}$ Brass Solder-coated
Potting Material	Epoxy (UL94V-0 rated)
Weight	(SIP/1.5g) (DIP/1.8g)
Dimensions	SIP Case 0.46"x0.24"x0.40" DIP Case 0.50"x0.40"x0.27"

ABSOLUTE MAXIMUM RATINGS(4)	
These are stress ratings. Exposure of devices to any of these conditions may adversely affect long-term reliability.	
Input Surge Voltage(100ms)	
3.3 Models	6 Vdc, max.
5 Models	7 Vdc, max.
12 Models	15 Vdc, max.
15 Models	18 Vdc, max.
24 Models	28 Vdc, max.
Soldering Temperature (1.5mm from case 10sec max.)	260°C, max.

EMC SPECIFICATIONS		
Radiated Emissions	EN55032	CLASS B
Conducted Emissions (6)	EN55032	CLASS B
ESD	IEC 61000-4-2	Perf. Criteria A
RS	IEC 61000-4-3	Perf. Criteria A
EFT (7)	IEC 61000-4-4	Perf. Criteria A
Surge (7)	IEC 61000-4-5	Perf. Criteria A
CS	IEC 61000-4-6	Perf. Criteria A
PFMF	IEC 61000-4-8	Perf. Criteria A

VA - 1W Unregulated Single output

PART NUMBER STRUCTURE

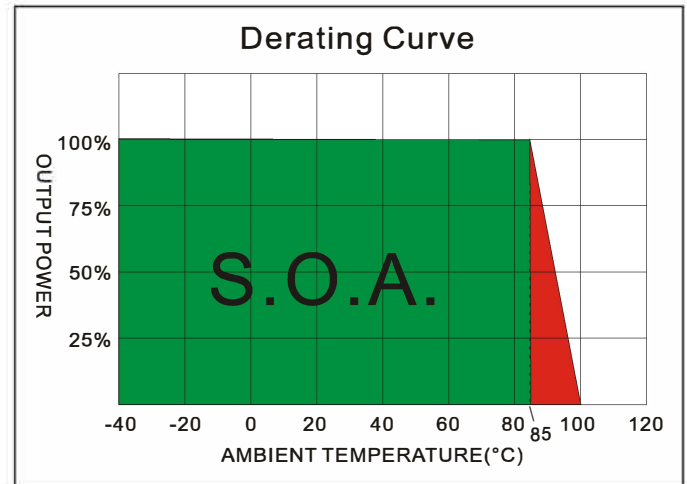
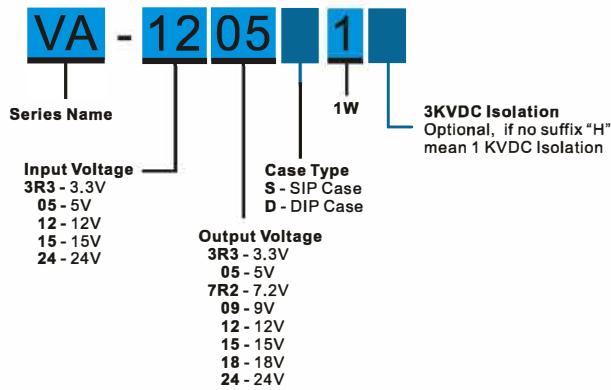

MODEL SELECTION GUIDE

MODEL NUMBER	INPUT Voltage Range	INPUT Current		OUTPUT Voltage (Vdc)	OUTPUT Current Full load (mA)	EFFICIENCY @FL (% , typ.)	Capacitor Load @FL (µF, max.)
		No-Load (mA, max.)	Full Load (mA, typ.)				
VA-3R33R3S1	3.3	25	421	3.3	303	72	220
VA-3R305S1	3.3	25	394	5	200	77	220
VA-3R37R2S1	3.3	25	384	7.2	138.9	79	220
VA-3R309S1	3.3	30	404	9	111.1	75	220
VA-3R312S1	3.3	45	473	12	100	77	220
VA-3R315S1	3.3	35	384	15	66.6	79	220
VA-3R318S1	3.3	35	399	18	55.5	76	220
VA-3R324S1	3.3	53	461	24	50	79	220
VA-053R3S1	5	20	257	3.3	303	78	220
VA-0505S1	5	25	247	5	200	81	220
VA-057R2S1	5	16	241	7.2	138.9	83	220
VA-0509S1	5	26	250	9	111.1	80	220
VA-0512S1	5	25	300	12	100	80	220
VA-0515S1	5	35	244	15	66.6	82	220
VA-0518S1	5	25	247	18	55.5	81	220
VA-0524S1	5	35	289	24	50	83	220
VA-123R3S1	12	15	107	3.3	303	78	220
VA-1205S1	12	16	105	5	200	79	220
VA-127R2S1	12	16	100	7.2	138.9	83	220
VA-1209S1	12	15	107	9	111.1	78	220
VA-1212S1	12	20	125	12	100	80	220
VA-1215S1	12	15	105	15	66.6	79	220
VA-1218S1	12	20	104	18	55.5	80	220
VA-1224S1	12	25	123	24	50	71	220
VA-153R3S1	15	15	89	3.3	303	75	220
VA-1505S1	15	9	82	5	200	81	220
VA-157R2S1	15	12	88	7.2	138.9	76	220
VA-1509S1	15	10	90	9	111.1	74	220
VA-1512S1	15	13	100	12	100	80	220
VA-1515S1	15	15	84	15	66.6	79	220
VA-1518S1	15	12	85	18	55.5	78	220
VA-1524S1	15	10	99	24	50	81	220

Suffix "H" means 3 KVdc isolation

VA - 1W Unregulated Single output

MODEL NUMBER	INPUT Voltage Range	INPUT Current		OUTPUT Voltage (Vdc)	OUTPUT Current Full load (mA)	EFFICIENCY @FL (% , typ.)	Capacitor Load @FL (µF, max.)
		No-Load (mA, max.)	Full Load (mA, typ.)				
VA-243R3S1	24	8	54	3.3	303	77	220
VA-2405S1	24	8	52	5	200	80	220
VA-247R2S1	24	10	54	7.2	138.9	77	220
VA-2409S1	24	7	54	9	111.1	77	220
VA-2412S1	24	8	62	12	100	80	220
VA-2415S1	24	8	51	15	66.6	81	220
VA-2418S1	24	8	52	18	55.5	80	220
VA-2424S1	24	9	60	24	50	83	220
VA-3R33R3D1	3.3	25	410	3.3	303	74	220
VA-3R305D1	3.3	25	394	5	200	77	220
VA-3R37R2D1	3.3	30	404	7.2	138.9	75	220
VA-3R309D1	3.3	30	399	9	111.1	76	220
VA-3R312D1	3.3	45	485	12	100	75	220
VA-3R315D1	3.3	25	384	15	66.6	79	220
VA-3R318D1	3.3	35	399	18	55.5	76	220
VA-3R324D1	3.3	90	485	24	50	75	220
VA-053R3D1	5	16	256	3.3	303	78	220
VA-0505D1	5	15	253	5	200	79	220
VA-057R2D1	5	16	241	7.2	138.9	83	220
VA-0509D1	5	25	253	9	111.1	79	220
VA-0512D1	5	25	296	12	100	81	220
VA-0515D1	5	25	244	15	66.6	82	220
VA-0518D1	5	25	241	18	55.5	83	220
VA-0524D1	5	28	293	24	50	82	220
VA-123R3D1	12	15	108	3.3	303	77	220
VA-1205D1	12	16	105	5	200	79	220
VA-127R2D1	12	16	100	7.2	138.9	83	220
VA-1209D1	12	15	105	9	111.1	79	220
VA-1212D1	12	20	125	12	100	80	220
VA-1215D1	12	17	105	15	66.6	79	220
VA-1218D1	12	15	103	18	55.5	81	220
VA-1224D1	12	25	127	24	50	79	220
VA-153R3D1	15	15	89	3.3	303	75	220
VA-1505D1	15	10	83	5	200	80	220
VA-157R2D1	15	12	88	7.2	138.9	76	220
VA-1509D1	15	10	85	9	111.1	78	220
VA-1512D1	15	13	98	12	100	82	220
VA-1515D1	15	15	83	15	66.6	80	220
VA-1518D1	15	12	85	18	55.5	78	220
VA-1524D1	15	10	99	24	50	81	220
VA-243R3D1	24	8	53	3.3	303	79	220
VA-2405D1	24	8	53	5	200	79	220
VA-247R2D1	24	10	56	7.2	138.9	74	220
VA-2409D1	24	7	53	9	111.1	79	220
VA-2412D1	24	8	63	12	100	80	220
VA-2415D1	24	8	52	15	66.6	80	220
VA-2418D1	24	8	51	18	55.5	82	220
VA-2424D1	24	9	61	24	50	82	220

Suffix "H" means 3 KVdc isolation

TEST CONFIGURATIONS
Input Reflected Ripple Current Test Step

Input reflected ripple current is measured through a source inductor L_{in} ($12\mu H$) and a source capacitor C_{in} ($47\mu F$, $ESR < 1.0\Omega$ at $100KHz$) at nominal input and full load.

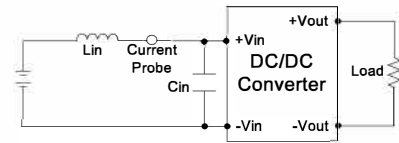

Output Ripple & Noise Measurement Test

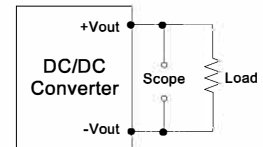
The Scope measurement bandwidth is 20MHz .

EMI Filter

Input filter components ($C1$, L , $C2$, $C3$) are used to help meet conducted emissions requirement for the module.

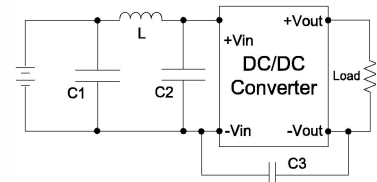
These components should be mounted as close as possible to the module; and all leads should be minimized to decrease radiated noise.



	C1	L	C2	C3
VA-3R3XXXXX	1210, 2.2 μF /100V	18 μH		
VA-05XXXXXX	1210, 2.2 μF /100V	18 μH		
VA-12XXXXXX	1210, 2.2 μF /100V	18 μH		
VA-15XXXXXX	1210, 2.2 μF /100V	18 μH		
VA-24XXXXXX	1210, 2.2 μF /100V	18 μH	1210, 2.2 μF /100V	1206, 470pF/2KV

NOTE

1. Ripple/Noise measured with 20MHz bandwidth.
2. Tested by minimal V_{in} and constant resistive load.
3. Measured Input reflected ripple current with a simulated source inductance of $12\mu H$ and a source capacitor C_{in} ($47\mu F$, $ESR < 1.0\Omega$ at $100KHz$).
4. Exceeding the absolute ratings of the unit could cause damage. It is not allowed for continuous operating.
5. Operation under no-load conditions will not damage these devices, however they may not meet all listed specifications.
6. Input filter components are required to help meet conducted emission class B, which application refer to the EMI Filter of design & feature configuration.
7. An external filter capacitor is required if the module has to meet IEC61000-4-4 and IEC61000-4-5.
The filter capacitor Motien suggest: Nippon - chemi - con KY series, $470\mu F/100V$.

VA - 1W Unregulated Single output

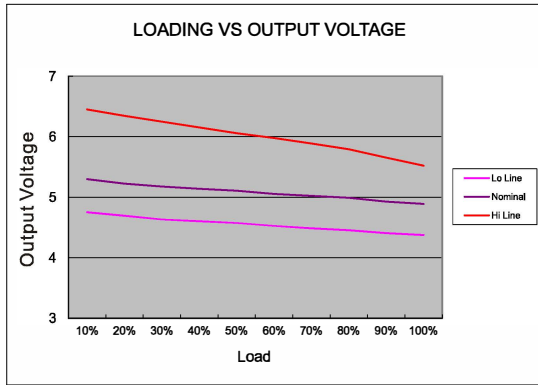

05 Models

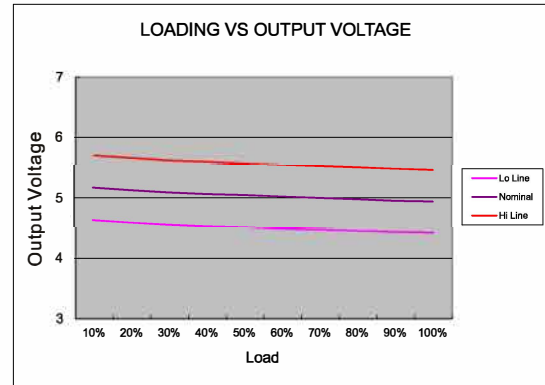

12 Models

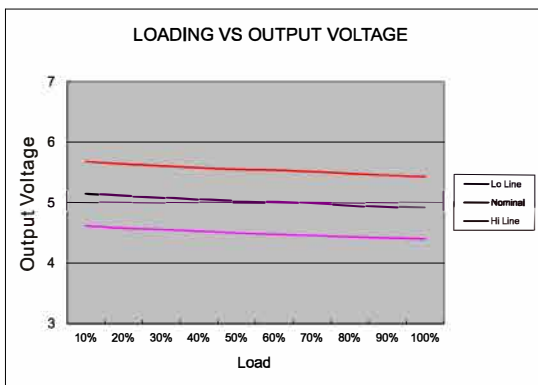

24 Models

MECHANICAL SPECIFICATIONS

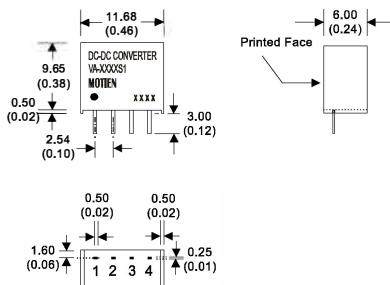

4 Pin SIL Package

- Notes : All dimensions are typical in millimeters (inches).
1. Pin diameter: 0.5 ± 0.05 (0.02 ± 0.002)
 2. Pin pitch and length tolerance: ± 0.35 (± 0.014)
 3. Case Tolerance: ± 0.5 (± 0.02)

PIN CONNECTIONS

PIN NUMBER	SINGLE
1	-V Input
2	+V Input
3	-V Output
4	+V Output

(The Pin Connection of high isolation one is the same with normal one.)

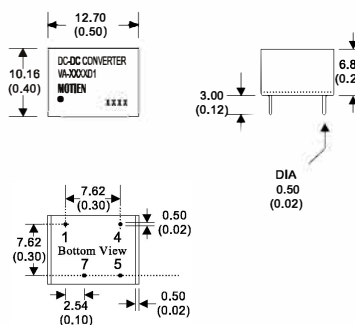

8 Pin DIL Package

- Notes : All dimensions are typical in millimeters (inches).
1. Pin diameter: 0.5 ± 0.05 (0.02 ± 0.002)
 2. Pin pitch and length tolerance: ± 0.35 (± 0.014)
 3. Case Tolerance: ± 0.5 (± 0.02)

PIN CONNECTIONS

PIN NUMBER	SINGLE
1	-V Input
4	+V Input
5	+V Output
7	-V Output

(The Pin Connection of high isolation one is the same with normal one.)