

M9 - 20W Series

20W 4:1 Regulated Single & Dual output



electronicsolutions

Features

- Ultra Wide 4:1 Input Range
- 3000 VDC Isolation
- No Minimum Load Required
- Efficiency up to 91%
- Extended Operating Temperature Range -40 ~ 100°C max.
- Adjustable Output Voltage
- Remote On/Off Control (CTRL)
- Continuous Short Circuit Protection
- Over Load Protection
- Over Voltage Protection
- Soft Start
- Built-in EMI filter meets EN55032 classA without external components



The M9 series is a family of cost effective 20W single & dual output DC-DC converters. These converters combine copper package in a 1.6"x1" case with high performance features, continuous short circuit protection with automatic restart and tight line / load regulation. Devices are encapsulated using flame retardant resin. Input voltages of 24 and 48 with output voltage of 3.3, 5, 12, 15, ± 5 , ± 12 , ± 15 Vdc. High performance features include high efficiency operation up to 91% and output voltage accuracy of $\pm 1\%$ maximum.

ALL SPECIFICATIONS ARE TYPICAL AT 25°C, NOMINAL INPUT AND FULL LOAD UNLESS OTHERWISE NOTED.

OUTPUT SPECIFICATIONS		GENERAL SPECIFICATIONS	
Output Voltage Accuracy	$\pm 1\%$	Efficiency	See table, typ.
Output Voltage Adjustability(Trim)	Single output: $\pm 10\%$, max.	I/O Isolation Voltage(60sec)	
Maximum Output Current	See table	Input/Output	3000Vdc
Line Regulation	$\pm 0.5\%$, max.	Case/Input & Output	1600Vdc
Load Regulation($I_o=0\%$ to 100%)	Single: $\pm 0.5\%$, max. Dual: $\pm 1\%$, max.(balanced load)	Isolation Resistance	1000 M Ω , min.
Cross Regulation (Dual Output) (1)	$\pm 5\%$	Isolation Capacitance	2000 pF, typ.
Ripple&Noise		Switching Frequency 3.3 & 05 Vout Models	270kHz, typ.
Measured by 20MHz bandwidth		other Models	330kHz, typ.
With a 10 μ F/25V X7R MLCC	Single output:75mVpk-pk,max.	Humidity	95% rel H
With a 10 μ F/25V X7R MLCC for each output	Dual output:60mVpk-pk,max.	Reliability Calculated MTBF(MIL-HDBK-217 F)	>400 Khrs
Over Voltage Protection	140% of Vout, typ.	Safety Standard	UL/cUL 60950-1 , 62368-1 IEC/EN 60950-1 , 62368-1
Over Load Protection	170% of FL, typ.	Safety Approvals	UL/cUL 60950-1 , 62368-1 IEC/EN 60950-1 , 62368-1
Short Circuit Protection	Indefinite(hiccup) (Automatic Recovery)	EMC CHARACTERISTICS	
Temperature Coefficient	$\pm 0.02\%/^{\circ}\text{C}$	Radiated Emissions	EN55032 CLASS A
Capacitive Load (2)	See table	Conducted Emissions	EN55032 CLASS A
Transient Recovery Time (3)	250 μ s, typ.	ESD	IEC61000-4-2 Perf. Criteria B
Transient Response Deviation(3)	$\pm 3\%$, max. Single Output 3.3V: $\pm 5\%$, max.	RS	IEC61000-4-3 Perf. Criteria A
INPUT SPECIFICATIONS		EFT(8)	IEC61000-4-4 Perf. Criteria A
Input Voltage Range	See table	Surge (8)	IEC61000-4-5 Perf. Criteria A
Under Voltage Lockout		CS	IEC61000-4-6 Perf. Criteria A
24V Modes Module ON / OFF	8.8Vdc / 7.6Vdc, typ.	PFMF	IEC61000-4-8 Perf. Criteria A
48V Modes Module ON / OFF	17.5Vdc / 16.5Vdc, typ.	PHYSICAL SPECIFICATIONS	
Start up Time	30mS, typ.	Case Material	Copper
(Nominal Vin and constant resistive load)		Base Material	Non-conductive Black Plastic(UL94V-0 rated)
Input Filter	Pi Type	Pin Material	$\Phi 1.0$ mm Brass Solder-coated
Input Current(No-Load)	See table, max.	Potting Material	Epoxy (UL94V-0 rated)
Input Current(Full-Load)	See table, typ.	Weight	29.0g(Without Heat-sink) / 35.5g(With Heat-sink)
Input Reflected Ripple Current(4)	20mA _{p-p} , typ.	Dimensions	1.60"x1.00"x0.41"
Remote On/Off (Positive logic)(5)		ABSOLUTE SPECIFICATIONS (6)	
ON:	3.0 ... 12Vdc or open circuit	These are stress ratings. Exposure of devices to any of these conditions may adversely affect long-term reliability.	
OFF:	0 ... 1.2Vdc or Short circuit pin2 and pin6	Input Voltage(100mS)	50 Vdc, max. 100 Vdc, max.
OFF idle current:	2 mA, typ.	24 Models	
		48 Models	
		Soldering Temperature(1.5mm from case 10sec Max.)	260°C, max.
ENVIRONMENTAL SPECIFICATIONS			
Operating Ambient Temperature	-40°C ~ +100°C(See Derating Curve) -40°C ~ +66°C(For 100% load)		
Maximum Case Temperature	105°C		
Thermal Impedance	Without Heat-sink 12°C/W, min. With Heat-sink 11°C/W, min.		
Storage Temperature	-55°C ~ +125°C		
Cooling(7)	Nature Convection		

M9 - 20W 4:1 Regulated Single & Dual output

PART NUMBER STRUCTURE

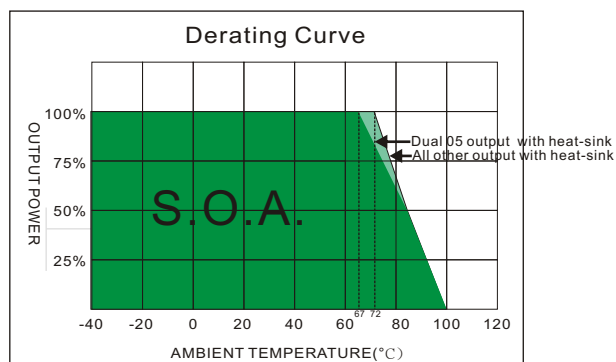
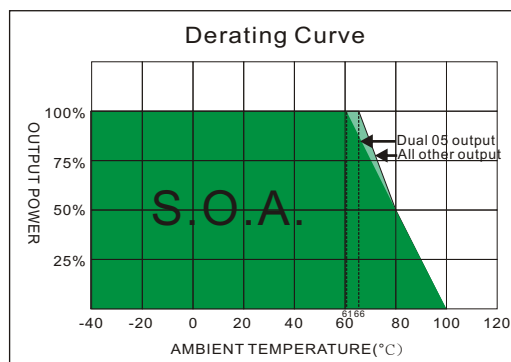
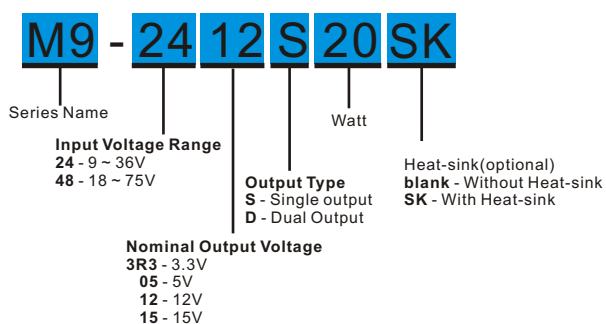

MODEL SELECTION GUIDE

MODEL NUMBER	INPUT Voltage Range (Vdc)	INPUT Current		OUTPUT Voltage (Vdc)	OUTPUT Current		EFFICIENCY @FL (% , typ.)	Capacitor Load @ FL (µF, max.)
		No-Load (mA, max.)	Full Load (mA, typ.)		Min. load (mA)	Full load (mA)		
M9-243R3S20	9-36	10	849.72	3.3	0	5500	89	10000
M9-2405S20	9-36	10	936.33	5	0	4000	89	6800
M9-2412S20	9-36	10	943.50	12	0	1670	88.5	1000
M9-2415S20	9-36	15	944.60	15	0	1330	88	680
M9-483R3S20	18-75	8	422.49	3.3	0	5500	89.5	10000
M9-4805S20	18-75	8	462.96	5	0	4000	90	6800
M9-4812S20	18-75	8	463.89	12	0	1670	90	1000
M9-4815S20	18-75	8	456.73	15	0	1330	91	680
M9-2405D20	9-36	10	968.99	±5	0	±2000	86	±2200
M9-2412D20	9-36	15	943.50	±12	0	±835	88.5	±470
M9-2415D20	9-36	15	939.27	±15	0	±665	88.5	±330
M9-4805D20	18-75	8	478.93	±5	0	±2000	87	±2200
M9-4812D20	18-75	8	463.89	±12	0	±835	90	±470
M9-4815D20	18-75	10	459.25	±15	0	±665	90.5	±330

NOTE

- One load is 25% to 100% load, the other load is 100% load, the output voltage variable rate is within ±5%.
- Tested by minimal V_{in} and constant resistive load.
- Tested by normal V_{in} and 25% load step change (75%-50%-25% of I_o).
- Measured Input reflected ripple current with a simulated source inductance of 12µH and a source capacitor C_{in} (47µF, ESR<1.0Ω at 100KHz).
- The remote on/off control pin is referenced to -Vin(pin2).
- Exceeding the absolute ratings of the unit could cause damage.
It is not allowed for continuous operating.
- "Nature Convection" is usually about 30-65 LFM but is not equal to still air (0 LFM).
- An external filter is required if the module has to meet IEC61000-4-4,EN61000-4-5.
The M9-24XXXX20 recommended an aluminum electrolytic capacitor (Nippon chemi-con KY series, 330µF/100V) and a TVS (SMDJ58A,58V,3000Watt peak pulse power) to connect in parallel.
The M9-48XXXX20 recommended an aluminum electrolytic capacitor (Nippon chemi-con KY series, 330µF/100V) and a TVS (SMDJ120A,120V,3000Watt peak pulse power) to connect in parallel.
Which application refer to the EFT/Surge Filter of design & feature configuration.

TEST CONFIGURATIONS

Input Reflected Ripple Current Test Step

Input reflected ripple current is measured through a source inductor L_{in} ($12\mu H$) and a source capacitor C_{in} ($47\mu F$, $ESR < 1.0\Omega$ at $100KHz$) at nominal input and full load.

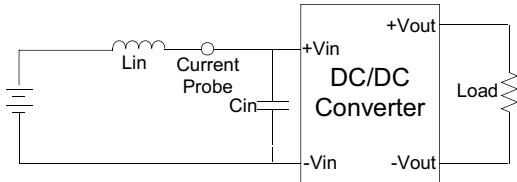

Output Ripple & Noise Measurement Test

To reduce ripple and noise, it is recommended to use a $10\mu F$ ceramic disk capacitor to at the output.

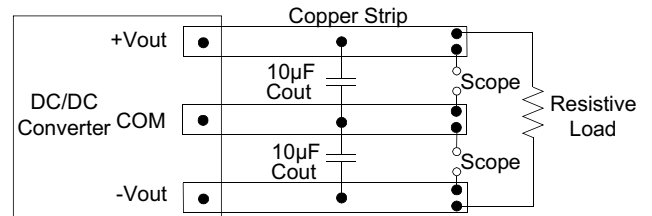

DESIGN & FEATURE CONFIGURATIONS

Over Voltage Protection

The module includes an internal output over voltage protection circuit, which monitors the voltage on the output terminals. If this voltage exceeds the over voltage set point, the module will activate the control loop of internal circuit to clamp the output voltage.

Over Current Protection

The module includes an internal over current protection circuit, which will endure current limiting for an unlimited duration during output over load condition. If the output current exceeds the OCP set point, the module will shut down automatically (hiccup).

The module will try to restart after shut down. If the over load condition still exists, the module will shut down again.

CTRL Module ON / OFF

Positive logic turns on the module during high logic and off during low logic.

Ctrl module on/off can be controlled by an external switch between the ctrl terminal and -Vin terminal. The switch can be an open collector or open drain

For positive logic if the ctrl feature is not used, please leave the ctrl pin floating.

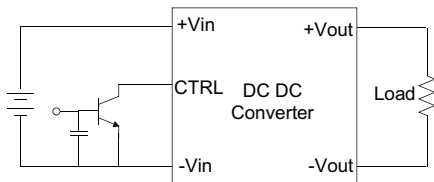

EFT/ Surge Filter

Input filter components (C1, D1) are used to help meet EN61000-4-4 and EN61000-4-5 .

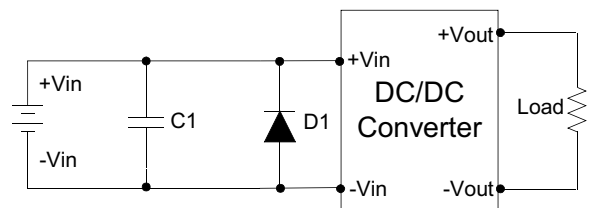

	C1	D1
M9-24XXXXX	330µF, 100V	TVS, 58V, 3kW
M9-48XXXXX	330µF, 100V	TVS, 120V, 3kW

M9 - 20W 4:1 Regulated Single & Dual output

MECHANICAL SPECIFICATIONS

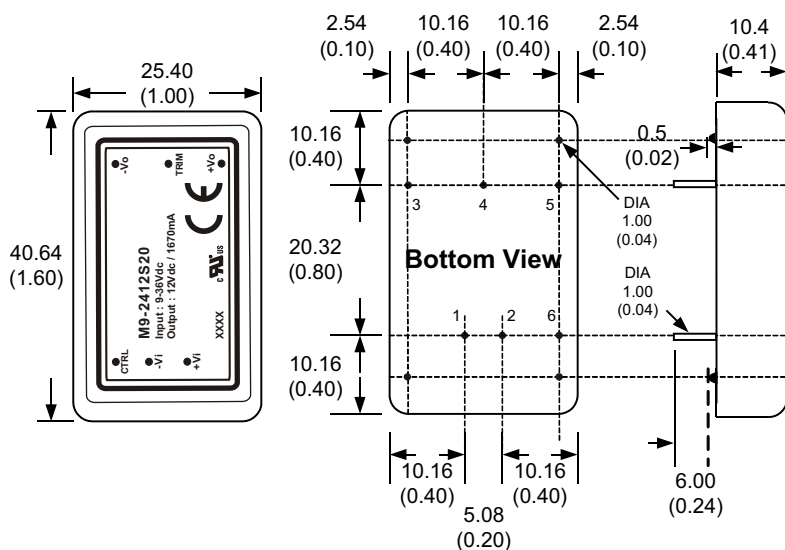

PIN CONNECTIONS		
PIN NUMBER	SINGLE	DUAL
1	+Vin	+Vin
2	-Vin	-Vin
3	+Vout	+Vout
4	Trim	Com
5	-Vout	-Vout
6	CTRL	CTRL

EXTERNAL OUTPUT TRIMMING

Output can be externally trimmed by using the method as below. (single output models only)

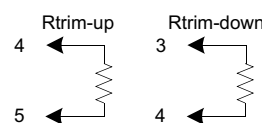

All dimensions are typical in millimeters (inches).

1. Pin diameter: 1.0 ± 0.05 (0.04 ± 0.002)
2. Pin pitch tolerance: ± 0.35 (± 0.014)
3. Case Tolerance: ± 0.5 (± 0.02)
4. Stand-off tolerance: ± 0.1 (± 0.004)

MECHANICAL SPECIFICATIONS

With Heat-sink

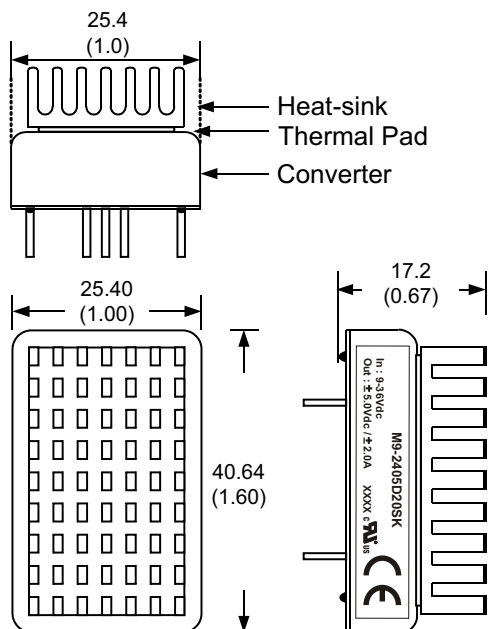

Order code: M9-XXXXS20SK (contain: heat-sink, thermal pad)
 Material: Aluminum
 Finish: Anodic treatment (black)
 Weight: 6.5 g (0.23oz) (without converter)

Note:

1. Converters will be supplied with heat-sinks already mounted. Please contact factory for quotation.