

# MK-6W Series

6W 4:1 Regulated Single & Dual output



electronicpowersolutions

## Features

- Wide 4:1 Input Range
- Full SMD Technology
- 1500VDC Isolation, Up to 3000VDC
- Continuous Short Circuit Protection
- Efficiency up to 85%
- -40°C~ 85°C Operation Temperature Range
- EMC filter meets EN55032 Class A without adding external components
- Non-conductive Black Plastic DIL24-pin case



The MK series is a family of cost effective 6W single & dual output DC-DC converters. These converters combine Plastic case in a 24-pin DIL package with high performance features such as 1500VDC ~ 3000VDC input/output isolation voltage, continuous short circuit protection with automatic restart and high line / load regulation. Devices are encapsulated using flame retardant resin. Input voltages are 24Vdc and 48Vdc, with output voltages are 3.3, 5, 12, 15, 24,  $\pm 3.3$ ,  $\pm 5$ ,  $\pm 12$ ,  $\pm 15$  and  $\pm 24$  Vdc. Featuring high efficiency operation up to 85% and output voltage accuracy of  $\pm 2\%$  maximum. Also, no additional components adding required to comply with EN55032 Class A.

All specifications typical at Ta=25°C, nominal input voltage and full load unless otherwise specified.

OUTPUT SPECIFICATIONS		GENERAL SPECIFICATIONS	
Output Voltage Accuracy	$\pm 2\%$ , max.	Efficiency	See table, typ.
Output Voltage Blance (Dual Output)	$\pm 2\%$ , max.	I/O Isolation Voltage(60sec) In <sub>put</sub> /Output	1500~3000Vdc
Output Current	See table, max.	I/O Isolation Capacitance	1000pF, typ.
Line Regulation	$\pm 0.5\%$ , max.	I/O Isolation Resistance	1000M $\Omega$ , min.
Load Regulation (0% to 100%)	$\pm 1.2\%$ , max.	Switching Frequency	330kHz, typ.
Cross Regulation (Dual Output) (1)	$\pm 5\%$ , max.	Humidity	95% rel H
Ripple & Noise (20MHz Bandwidth)(2)	80mVpk-pk, max. Dual Output 24V:100mVpk-pk, max.	Reliability Calculated MTBF(MIL-HDBK-217 F)	>800 Khrs
Over Load Protection	160% of I <sub>out</sub> , typ.	Safety Approvals	UL/cUL 60950-1 , 62368-1 IEC/EN 60950-1 , 62368-1
Short Circuit Protection	Indefinite(hiccup) (Automatic Recovery)		
Temperature Coefficient	$\pm 0.02\%/^{\circ}\text{C}$	PHYSICAL SPECIFICATIONS	
Capacitive Load (3)	See table, max.	Case Material	Non-conductive Black Plastic(UL94V-0 rated)
Transient Recovery Time (4)	300 $\mu\text{s}$ , typ.	Base Material	Non-conductive Black Plastic(UL94V-0 rated)
Transient Response Deviation (4)	$\pm 3\%$ , max. Single Output 3.3V: $\pm 5\%$ , max.	Pin Material	$\Phi 0.5\text{mm}$ Brass Solder-coated
		Potting Material	Epoxy (UL94V-0 rated)
		Weight	13.0g
		Dimensions	1.25"x0.8"x0.4"
INPUT SPECIFICATIONS		ENVIRONMENT SPECIFICATIONS	
Input Voltage Range	See table	Operating Temperature	-40°C~85°C(See Derating Curve) -40°C ~ +60°C (For 100% load)
Under Voltage Lockout		Maximum Case Temperature	100°C
24 Models Module ON / OFF	8.5Vdc / 7.0Vdc, typ.	Storage Temperature	-55°C~125°C
48 Models Module ON / OFF	16.5Vdc / 14.5Vdc, typ.	Cooling	Nature Convection
Start up Time (Nominal Vin and constant resistive load)	20mS, typ.		
Input Filter	Pi Type	ABSOLUTE MAXIMUM RATINGS(7)	
Input Current (No-Load)	See table, max.	These are stress ratings. Exposure of devices to any of these conditions may adversely affect long-term reliability.	
Input Current (Full-Load)	See table, typ.	Input Surge Voltage (100mS)	
Input Reflected Ripple Current (5)	20mA <sub>p-p</sub> , typ.	24 Models	50Vdc, max.
		48 Models	100Vdc, max.
		Soldering Temperature	260°C, max. (1.5mm from case 10sec max.)
EMC SPECIFICATIONS			
Radiated Emissions	EN55032 CLASS A		
Conducted Emissions	EN55032 CLASS A		
ESD	IEC 61000-4-2 Perf. Criteria A		
RS	IEC 61000-4-3 Perf. Criteria A		
EFT	IEC 61000-4-4 Perf. Criteria A		
Surge (6)	IEC 61000-4-5 Perf. Criteria A		
CS	IEC 61000-4-6 Perf. Criteria A		
PFMF	IEC 61000-4-8 Perf. Criteria A		

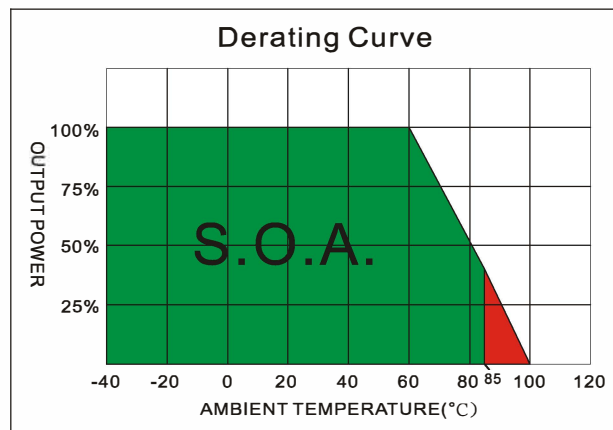
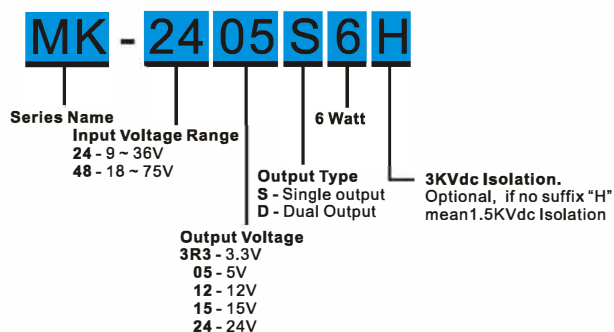
**MK - 6W 4:1 Regulated Single & Dual output**
**PART NUMBER STRUCTURE**

**MODEL SELECTION GUIDE**

MODEL NUMBER	INPUT Voltage Range (Vdc)	INPUT Current		OUTPUT Voltage (Vdc)	OUTPUT Current		EFFICIENCY @FL (% , typ.)	Capacitor Load @FL (µF, max.)
		No-Load (mA, max.)	Full Load (mA, typ.)		Min. Load (mA)	Full Load (mA)		
MK-243R3S6	9-36	10	257	3.3	0	1400	76	470
MK-24 05S6	9-36	10	316	5	0	1200	80	470
MK-24 12S6	9-36	10	301	12	0	500	84	100
MK-24 15S6	9-36	10	301	15	0	400	84	100
MK-24 24S6	9-36	10	301	24	0	250	84	47
MK-243R3D6	9-36	10	325	±3.3	0	±909	78	±220
MK-24 05D6	9-36	10	309	±5	0	±600	82	±220
MK-24 12D6	9-36	10	301	±12	0	±250	84	±100
MK-24 15D6	9-36	15	301	±15	0	±200	84	±100
MK-24 24D6	9-36	20	309	±24	0	±125	82	±47
MK-483R3S6	18-75	7	128	3.3	0	1400	76	470
MK-48 05S6	18-75	7	154	5	0	1200	82	470
MK-48 12S6	18-75	7	151	12	0	500	84	100
MK-48 15S6	18-75	7	149	15	0	400	85	100
MK-48 24S6	18-75	7	149	24	0	250	85	47
MK-483R3D6	18-75	7	160	±3.3	0	±909	79	±220
MK-48 05D6	18-75	7	154	±5	0	±600	82	±220
MK-48 12D6	18-75	7	151	±12	0	±250	84	±100
MK-48 15D6	18-75	7	151	±15	0	±200	84	±100
MK-48 24D6	18-75	10	156	±24	0	±125	81	±47

Suffix "H" means 3000Vdc isolation

**NOTE**

- One load is 25% to 100% load, the other load is 100% load, the output voltage variable rate is within ±5%.
- Ripple/Noise measured with a 1µF ceramic capacitor.
- Tested by minimal Vin and constant resistive load.
- Tested by normal Vin and 25% load step change ( 75%-50%-25% of Io ).
- Measured Input reflected ripple current with a simulated source inductance of 12µH and a source capacitor Cin(47µF, ESR<1.0Ω at 100KHz).
- An external filter capacitor is required if the module has to meet IEC61000-4-5. The filter capacitor Motien suggest: Nippon chemi-con KY series, 220µF/100V.
- Exceeding the absolute ratings of the unit could cause damage. It is not allowed for continuous operating.

**TEST CONFIGURATIONS**
**Output Ripple & Noise Measurement Test**

Use a capacitor  $C_{out}(1.0\mu F)$  measurement.  
The Scope measurement bandwidth is 0-20MHz.

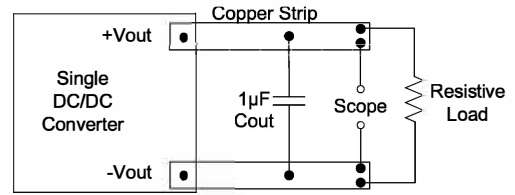
**Input Reflected Ripple Current Test Step**

Input reflected ripple current is measured through a source inductor  $L_{in}(12\mu H)$  and a source capacitor  $C_{in}(47\mu F, ESR < 1.0\Omega \text{ at } 100\text{KHz})$  at nominal input and full load.

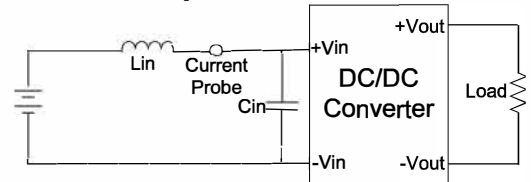
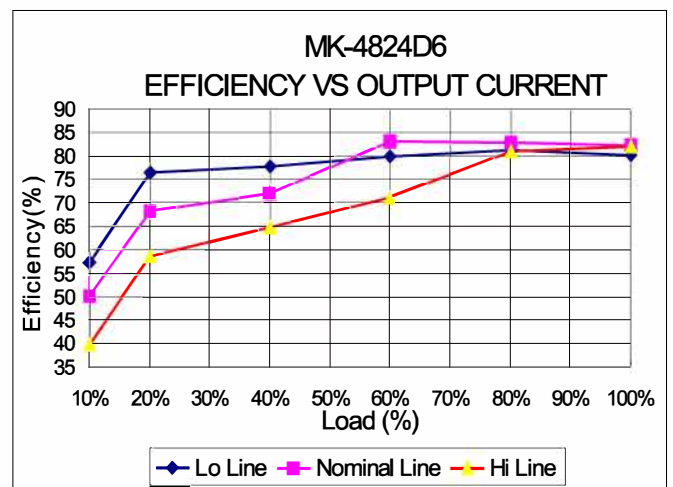
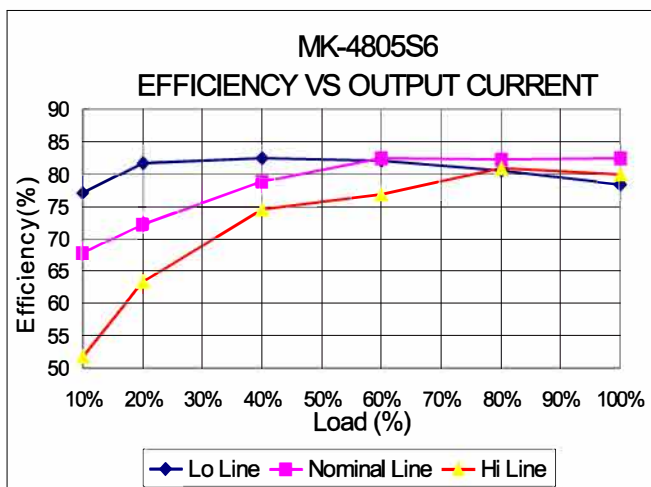
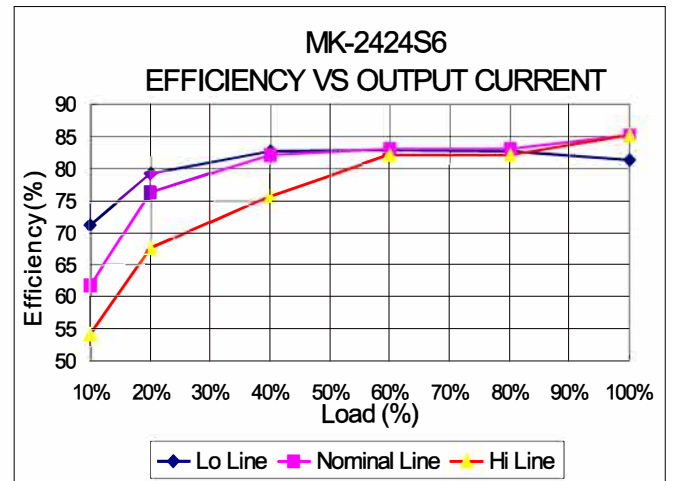
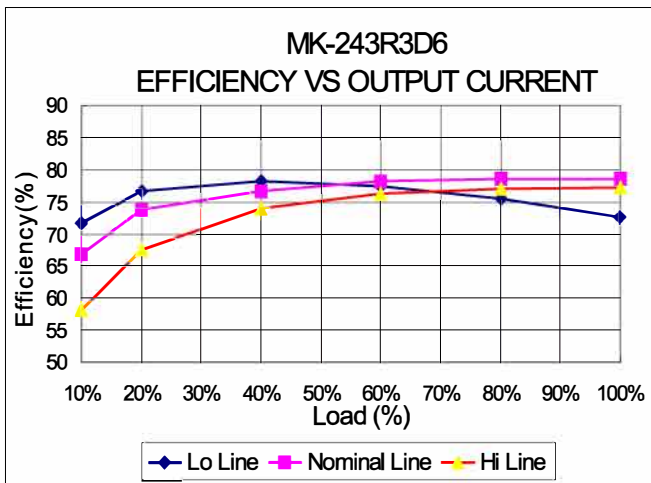
**ELECTRICAL CHARACTERISTIC CURVES**

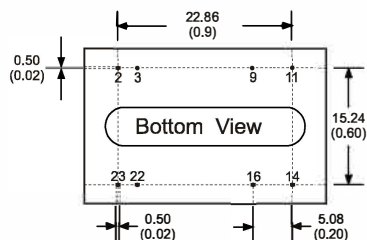
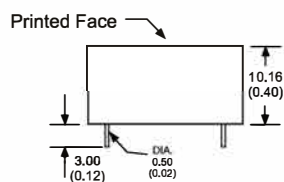
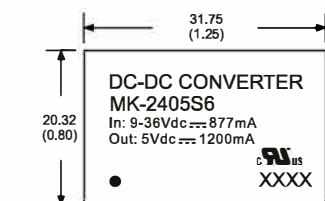
**MK - 6W 4:1 Regulated Single & Dual output**
**MECHANICAL SPECIFICATIONS**

**24 Pin DIL Package**  
**Non-Conductive Plastic**

Notes: All dimensions are typical in millimeters ( inches ).  
 1. Pin diameter:  $0.5 \pm 0.05$  (  $0.02 \pm 0.002$  )  
 2. Pin pitch and length tolerance:  $\pm 0.35$  (  $\pm 0.014$  )  
 3. Case Tolerance:  $\pm 0.5$  (  $\pm 0.02$  )

PIN CONNECTIONS		
PIN NUMBER	SINGLE	DUAL
2	-V Input	-V Input
3	-V Input	-V Input
9	N.P.	Common
11	N.C.	-V Output
14	+V Output	+V Output
16	-V Output	Common
22	+V Input	+V Input
23	+V Input	+V Input

(The Pin Connection of high isolation one is the same with normal one.)