

# VTW-60W Series

60W 4:1 Regulated Single & Dual output

## Features

- Wide 4:1 Input Range
- 1600VDC Isolation
- Efficiency up to 93%
- Extended Operating Temperature Range -40 ~ 100°C max.
- Adjustable Output Voltage
- Remote On/Off Control (CTRL)
- Continuous Short Circuit Protection
- Over Current Protection
- Over Voltage Protection
- Over Temperature Protection
- Soft Start
- No minimum load required



The VTW-60W series is a family of cost effective 60W single DC-DC converters. These converters combine copper package in a 2"x1" case with high performance features such as Active Clamp Technology, continuous short circuit protection with automatic restart and tight line / load regulation. Devices are encapsulated using flame retardant resin. Input voltages of 24 and 48 with output voltage of 5, 12, 15, ±12, ±15Vdc. High performance features include high efficiency operation up to 93%.

ALL SPECIFICATIONS ARE TYPICAL AT 25°C, NOMINAL INPUT AND FULL LOAD UNLESS OTHERWISE NOTED.

OUTPUT SPECIFICATIONS		GENERAL SPECIFICATIONS	
Output Voltage Accuracy	±1%, max.	Efficiency	See table, typ.
Output Voltage Adjustability (Trim)	±10%, max.	I/O Isolation Voltage (60sec)	
Maximum Output Current	See table	Input / Output	1600Vdc
Line Regulation	±0.5%, max.	Case / Input & Output	1600Vdc
Load Regulation (0% to 100%)	<b>Single:</b> ±0.5%, max. <b>Dual:</b> ±1%, max.	Isolation Resistance	1GΩ, min.
Cross Regulation (1)	<b>Dual:</b> ±5%	Isolation Capacitance	2200pF, typ.
Ripple & Noise (2)	100mVpk-pk, max.	Switching Frequency	225kHz, typ.
Over Voltage Protection	5V output 6.2V	Humidity	95% rel H
(Zener diode clamp)	12V output 15V	Reliability Calculated MTBF (MIL-HDBK-217 F)	>210khrs
	15V output 20V	Safety Approvals	UL/cUL 60950-1, 62368-1 IEC/EN 60950-1, 62368-1
Over Current Protection	140% of Iout, typ.	PHYSICAL SPECIFICATIONS	
Short Circuit Protection	Indefinite(hiccup) (Automatic Recovery)	Case Material	Copper
Temperature Coefficient	±0.02%/°C	Base Material	Non-conductive Black Plastic (UL94V-0 rated)
Capacitive Load (3)	See table, max.	Pin Material	Φ1.0mm Brass Solder-coated
Transient Recovery Time (4)	250µs, typ.	Potting Material	Epoxy (UL94V-0 rated)
Transient Response Deviation (4)	±3%, max.	Weight	45.0g(Without Heat-sink) / 56.3g(With Heat-sink)
		Dimensions	2.00"x1.00"x0.45"
INPUT SPECIFICATIONS		ABSOLUTE SPECIFICATIONS (8)	
Input Voltage Range	See table	These are stress ratings. Exposure of devices to any of these conditions may adversely affect long-term reliability.	
Under Voltage Lockout		Input Surge Voltage (100mS)	
24 Models Module ON / OFF	8.6Vdc / 7.9Vdc, typ.	24 Models	50Vdc, max.
48 Models Module ON / OFF	17.8Vdc / 16Vdc, typ.	48 Models	100Vdc, max.
Start up Time	60mS, typ.	Soldering Temperature	260°C, max.
(Nominal Vin and constant resistive load)		(1.5mm from case 10sec max.)	
Input Filter	Pi Type	EMC CHARACTERISTICS	
Input Current (No-Load)	See table, max.	Radiated Emissions (9)	EN55032 CLASS A
Input Current (Full-Load)	See table, typ.	Conducted Emissions (9)	EN55032 CLASS A
Input Reflected Ripple Current (5)	20mApk-pk, typ.	ESD	IEC61000-4-2 Perf. Criteria A
Remote On/Off (CTRL) (6)		RS	IEC61000-4-3 Perf. Criteria A
ON: 3.0 ... 12Vdc or open circuit		EFT (10)	IEC61000-4-4 Perf. Criteria A
OFF: 0 ... 1.2Vdc or Short circuit pin 2 and pin 3		Surge (10)	IEC61000-4-5 Perf. Criteria A
OFF idle current: 5mA, typ.		CS	IEC61000-4-6 Perf. Criteria A
		PFMF	IEC61000-4-8 Perf. Criteria A
ENVIRONMENTAL SPECIFICATIONS			
Operating Ambient Temperature	-40°C ~ +100°C(See Derating Curve)		
	-40°C ~ +50°C(For 100% load)		
Maximum Case Temperature	110°C		
Thermal Impedance	Without Heat-sink 9.5°C/W, min.		
(Mounting at FR4 (5.9*2.75 inch) PCB	With Heat-sink 8.5°C/W, min.		
Storage Temperature	-55°C ~ +125°C		
Over Temperature Protection (Case)	115°C, typ.		
Cooling(7)	Nature Convection		

## VTW - 60W 4:1 Regulated Single & Dual output

### PART NUMBER STRUCTURE

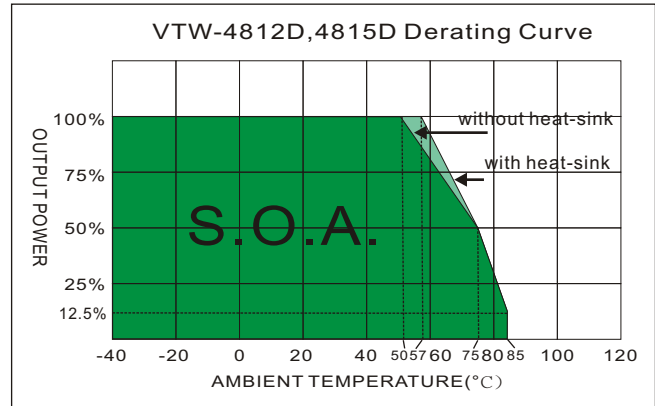
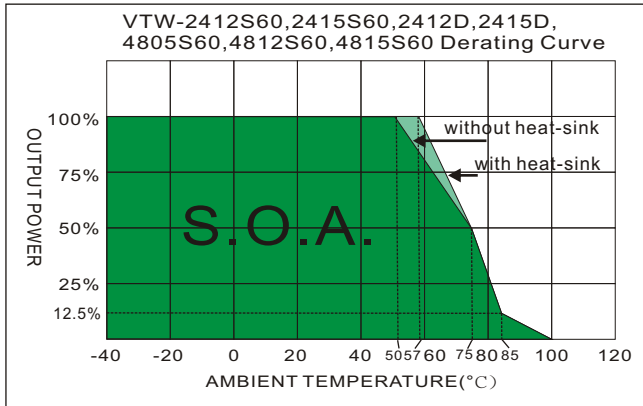
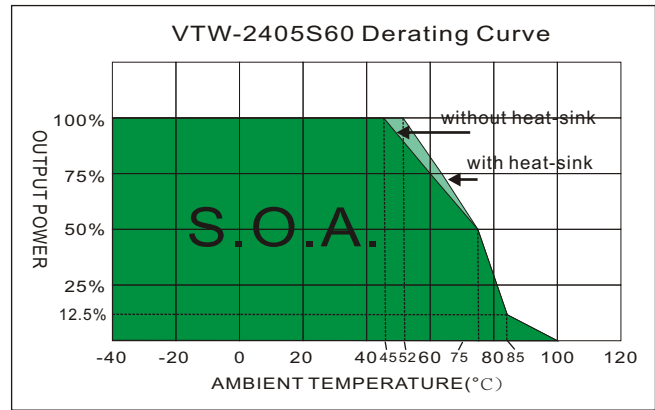
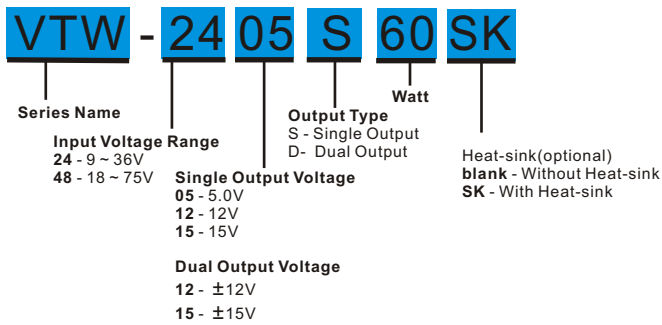

## MODEL SELECTION GUIDE

MODEL NUMBER	INPUT Voltage Range (Vdc)	INPUT Current		OUTPUT Voltage (Vdc)	OUTPUT Current		EFFICIENCY @FL (% , typ.)	Capacitor Load @FL (µF, max.)
		No-Load (mA, max.)	Full Load (mA, typ.)		Min. load (mA)	Full load (mA)		
VTW-2405S60	9-36, 24V Nominal	25	2703	5	0	12000	92.5	30000
VTW-2412S60	9-36, 24V Nominal	25	2703	12	0	5000	92.5	5850
VTW-2415S60	9-36, 24V Nominal	25	2688	15	0	4000	93	3900
VTW-4805S60	18-75, 48V Nominal	25	1344	5	0	12000	93	30000
VTW-4812S60	18-75, 48V Nominal	25	1351	12	0	5000	92.5	5850
VTW-4815S60	18-75, 48V Nominal	25	1344	15	0	4000	93	3900
VTW-2412D60	9-36, 24V Nominal	40	2747	±12	0	±2500	91	±3900
VTW-2415D60	9-36, 24V Nominal	50	2747	±15	0	±2000	91	±2400
VTW-4812D60	18-75, 48V Nominal	40	1373	±12	0	±2500	91	±3900
VTW-4815D60	18-75, 48V Nominal	50	1373	±15	0	±2000	91	±2400

### NOTE

- Dual: One load is 25% to 100% load, the other load is 100% load, the output voltage variable rate is within ±5%.
- Measured with 20MHz bandwidth and 1.0µF ceramic capacitor.
- Tested by minimal Vin and constant resistive load.
- Tested by normal Vin and 25% load step change ( 75%-50%-25% of Io ).
- Measured with a simulated source inductance of 1µH and a source capacitor Cin(22µF, ESR<1.0Ω at 100KHz).
- The remote on/off control pin is referenced to -Vin(pin2).
- "Nature Convection" is usually about 30-65 LFM but is not equal to still air (0 LFM).
- Exceeding the absolute ratings of the unit could cause damage. It is not allowed for continuous operating.
- The VTW-60W series can meet EN55032 Class A with an external filter in parallel with the input pins.
- An external filter capacitor is required if the module has to meet EN61000-4-4,EN61000-4-5.  
The VTW-24XXX60 recommended an aluminum electrolytic capacitor ( Nippon chemi-con KY series, 330µF/100V) and a TVS (SMDJ58A, 58V, 3000Watt peak pulse power) to connect in parallel.  
The VTW-48XXX60 recommended an aluminum electrolytic capacitor ( Nippon chemi-con KY series, 330µF/100V) and a TVS (SMDJ120A, 120V, 3000Watt peak pulse power) to connect in parallel.

**TEST CONFIGURATIONS**
**Input Reflected Ripple Current Test Step**

Input reflected ripple current is measured with a source inductor  $L_{in}$  ( $1\mu H$ ) and a source capacitor  $C_{in}$  ( $22\mu F$ ,  $ESR < 1.0\Omega$  at  $100KHz$ ) at nominal input and full load.

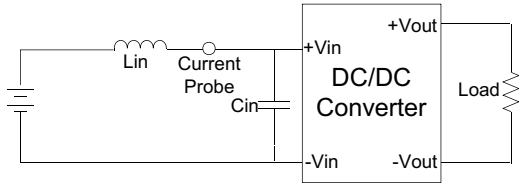
**Output Ripple & Noise Measurement Test**

Use a capacitor  $C_{out}$  ( $1.0\mu F$ ) measurement. The Scope measurement bandwidth is  $0-20MHz$ .

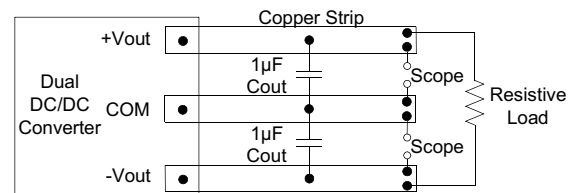
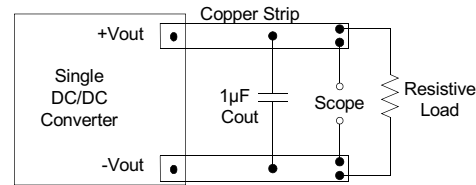
**DESIGN & FEATURE CONFIGURATIONS**
**Over Current Protection**

The module includes an internal over current protection circuit, which will endure current limiting for an unlimited duration during output over load condition. If the output current exceeds the OCP set point, the module will shut down automatically (hiccup).

The module will try to restart after shut down. If the over load condition still exists, the module will shut down again.

**Over Voltage Protection**

The module includes an internal output over voltage protection circuit, which monitors the voltage on the output terminals. If this voltage exceeds the over voltage set point, the module will activate the control loop of internal circuit to clamp the output voltage.

**CTRL Module ON / OFF**

Positive logic turns on the module during high logic and off during low logic.

Ctrl module on/off can be controlled by an external switch between the ctrl terminal and  $-V_{in}$  terminal.

The switch can be an open collector or open drain.

For positive logic if the ctrl feature is not used, please leave the ctrl pin floating.

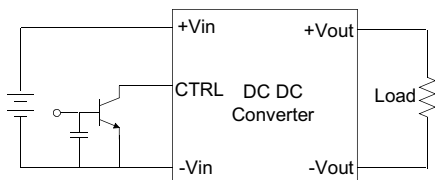

**Over Temperature Protection**

The over temperature protection consists of circuitry that provides protection from thermal damage. If the temperature exceeds the over temperature threshold the module will shut down.

The module will try to restart after shut down, If the over temperature condition still exists during restart, the module will shut down again. This restart trial will continue until the temperature is within specification.

**Output Ripple & Noise Reduction**

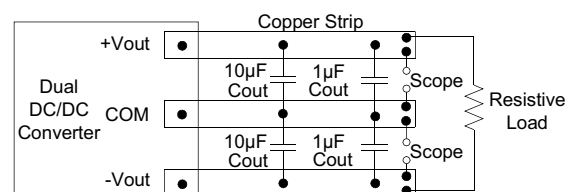
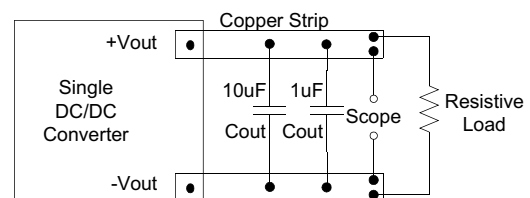
To reduce ripple and noise, it is recommended to use a  $1\mu F$  ceramic disk capacitor and a  $10\mu F$  ceramic disk capacitor to at the output.



## DESIGN &amp; FEATURE CONFIGURATIONS

**EMI Filter**

Input filter components (C1~C5,L1/L2) are used to help meet conducted emissions.

These components should be mounted as close as possible to the module; and all leads should be minimized to decrease radiated noise.

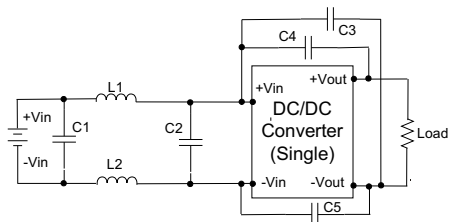

Single	C1	L1/L2	C2	C3	C4	C5
VTW-24XXSXX	1812,4.7 $\mu$ F, 50V	12 $\mu$ H	1812,4.7 $\mu$ F, 50V	1206,470pF, 2KV	1206,1000pF, 2KV	1206,1000pF, 2KV
VTW-48XXSXX	1812,1.5 $\mu$ F, 100V	12 $\mu$ H	1812,1.5 $\mu$ F, 100V	1206,470pF, 2KV	1206,1000pF, 2KV	1206,1000pF, 2KV

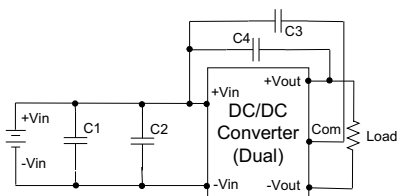

Dual	C1	C2	C3	C4
VTW-24XXDXX	1812,4.7 $\mu$ F, 50V	1812,4.7 $\mu$ F, 50V	1206,220pF, 2KV	1206,1500pF, 2KV
VTW-48XXDXX	1812,1.5 $\mu$ F, 100V	1812,1.5 $\mu$ F, 100V	1206,220pF, 2KV	1206,1500pF, 2KV

**EFT & SURGE Filter**

Input components (C1,D1) are used to help meet surge test requirement for the module.

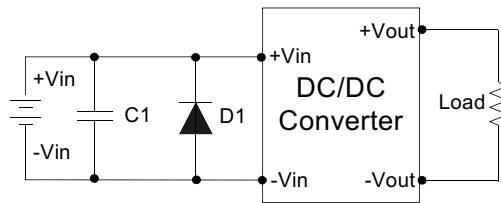

	C1	D1
VTW-24XXX60	330 $\mu$ F,100V	TVS,58V,3kW
VTW-48XXX60	330 $\mu$ F,100V	TVS,120V,3kW

D1:Transient Voltage Suppression Diodes

## ELECTRICAL CHARACTERISTIC CURVES

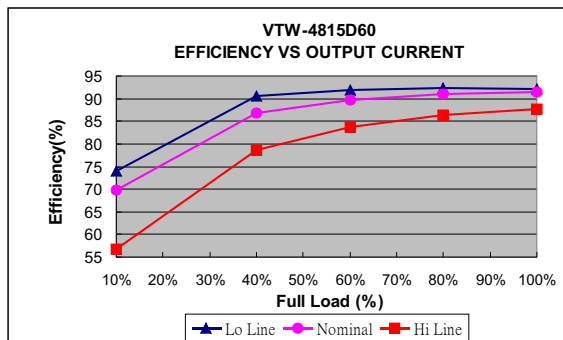
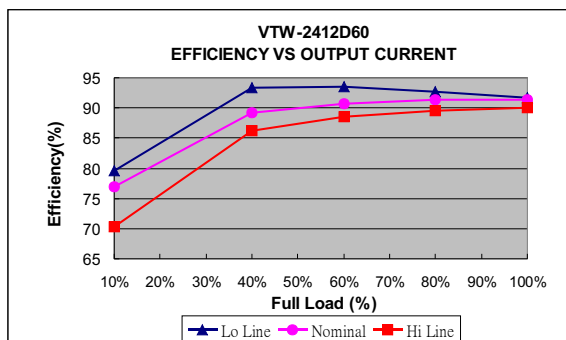
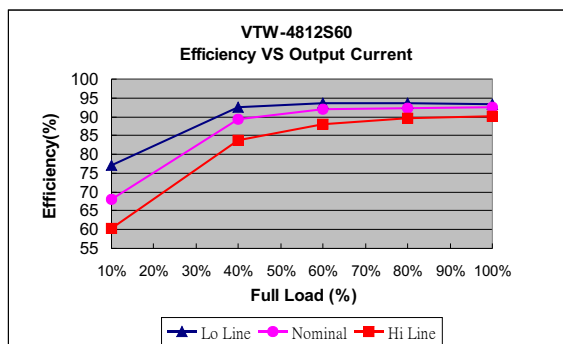
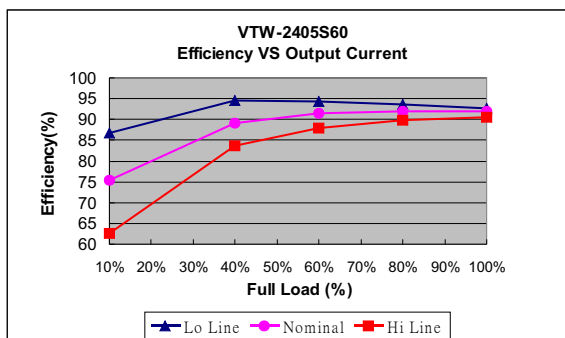

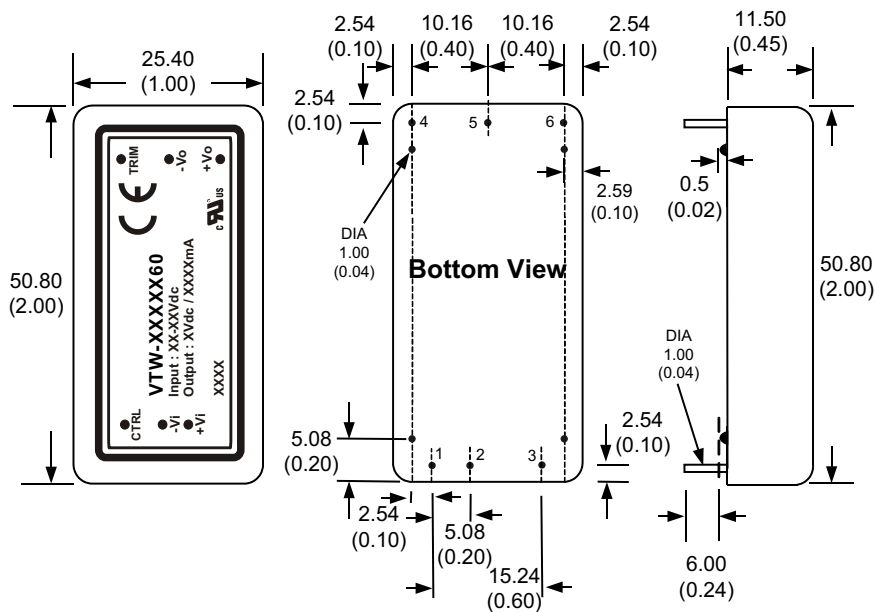
**VTW - 60W 4:1 Regulated Single & Dual output**
**MECHANICAL SPECIFICATIONS**

PIN CONNECTIONS		
PIN NUMBER	SINGLE	DUAL
1	+Vin	+Vin
2	-Vin	-Vin
3	CTRL	CTRL
4	+Vout	+Vout
5	-Vout	Com
6	Trim	-Vout

**EXTERNAL OUTPUT TRIMMING**

Output can be externally trimmed by using the method as below. (single output models only)

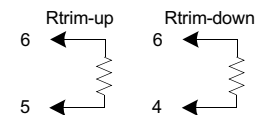

All dimensions are typical in millimeters ( inches ).

1. Pin diameter:  $1.0 \pm 0.05$  (  $0.04 \pm 0.002$  )
2. Pin pitch and length tolerance:  $\pm 0.35$  (  $\pm 0.014$  )
3. Case Tolerance:  $\pm 0.5$  (  $\pm 0.02$  )
4. Stand-off Tolerance:  $\pm 0.1$  (  $\pm 0.004$  )

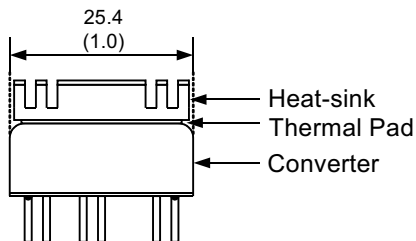
**With Heat-sink**

Order code: VTW-XXXXX60SK(contain: heat-sink, thermal pad)  
 Material: Aluminum  
 Finish: Anodic treatment (black)  
 Weight: 11.3g (0.40oz) (without converter)

Note:

1. Converters will be supplied with heat-sinks already mounted. Please contact factory for quotation.

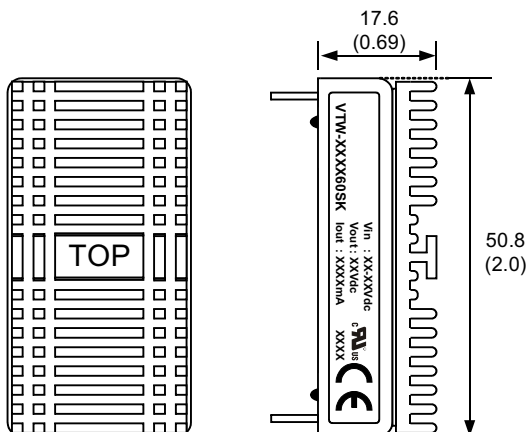

DRAWING: APPROVED: