

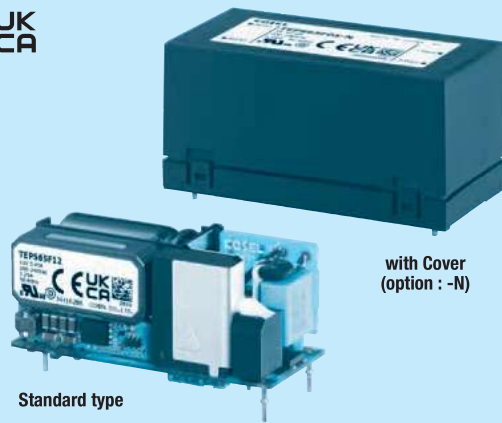

TEPS65F

TEP S 65 F -

① ② ③ ④ ⑤ ⑥



Standard type

with Cover
(option : -N)

Example recommended EMI/EMC filter
EAM-03-000



High voltage pulse noise type : EAP series
150KHz-1MHz (To safety ground the secondary
side) : EAC series

* A higher current rating EMI/EMC filter
may be recommended in view of the
other devices that could be connected
in parallel with the power supply.

- ① Series name
- ② Single output
- ③ Output wattage
- ④ Universal input
- ⑤ Output voltage
- ⑥ Optional *1
- E2: Low leakage current
- H : with output peak current (12V,24V)
- N : with cover
- For option details, refer to Instruction Manual 8.

Class II

This power supply is manufactured by SMD technology. The stress to PCB like twisting or bending causes the defect of the unit, so handle the unit with care.

*Make sure necessary tests will be carried out on your end equipment with the power supply installed in accordance with any required EMC/EMI regulations.

MODEL	TEPS65F05	TEPS65F12	TEPS65F12-H	TEPS65F24	TEPS65F24-H
MAX OUTPUT WATTAGE [W]	50.0	65.4	65.4 (90.0)	66.0	66.0 (90.0)
DC OUTPUT	5V 10.0A	12V 5.45A	12V 5.45 (7.50)A	24V 2.75A	24V 2.75 (3.75)A

SPECIFICATIONS

MODEL	TEPS65F05	TEPS65F12	TEPS65F12-H	TEPS65F24	TEPS65F24-H
INPUT	VOLTAGE [VAC] *2 85 - 264 1 φ (Refer to "Derating" and Instruction Manual 3.1) CURRENT [A] ACIN 100V 1.00typ / ACIN 230V 0.55typ FREQUENCY [Hz] 50 / 60 (45 - 66) EFFICIENCY [%] ACIN 100V 90.0typ / ACIN 230V 91.5typ INRUSH CURRENT [A] ACIN 100V 30typ (Io=100%) Ta=25°C at cold start / ACIN 230V 65typ (Io=100%) Ta=25°C at cold start LEAKAGE CURRENT [mA] 0.25max (ACIN 264V, 60Hz, Io=100%, According to IEC62368-1, and DEN-AN)				
OUTPUT	VOLTAGE [V] 5 / 12 / 12 / 24 / 24 CURRENT [A] *2 10.0 / 5.45 / 5.45 (Peak 7.50) / 2.75 / 2.75 (Peak 3.75) LINE REGULATION [mV] *3 20max / 48max / 48max / 96max / 96max LOAD REGULATION [mV] *3 40max / 100max / 100max / 150max / 150max RIPPLE[mVp-p] *4 -10 to +50°C *5 240max / 300max / 300max / 360max / 360max RIPPLE NOISE[mVp-p] *4 -10 to +50°C *5 300max / 380max / 380max / 480max / 480max TEMPERATURE REGULATION [mV] 0 to +50°C *5 50max / 120max / 120max / 240max / 240max DRIFT [mV] *6 -10 to +50°C *5 60max / 150max / 150max / 290max / 290max START-UP TIME [ms] *6 20max / 48max / 48max / 96max / 96max HOLD-UP TIME [ms] 500typ (ACIN 100/230V, Io=100%) / 10typ (ACIN 100V, Io=80%) / 60typ (ACIN 230V, Io=100%) OUTPUT VOLTAGE SETTING [V] 4.90 to 5.30 / 11.50 to 12.50 / 11.50 to 12.50 / 23.00 to 25.00 / 23.00 to 25.00				
PROTECTION CIRCUIT AND OTHERS	OVERCURRENT PROTECTION Works over 105% of rating (works over 101% of peak current at option -H) and recovers automatically OVERVOLTAGE PROTECTION [V] 5.50 to 6.50 / 13.20 to 15.60 / 13.20 to 15.60 / 26.40 to 31.20 / 26.40 to 31.20 OPERATING INDICATION Not provided REMOTE SENSING Not provided				
ISOLATION	INPUT-OUTPUT 3,000VAC 1minute, Cutoff current = 10mA, 500VDC 100MΩ min (At Room Temperature)				
ENVIRONMENT	OPERATING TEMP., HUMID. AND ALTITUDE *2 -10 to +70°C, 20 - 90%RH (Non condensing), (Refer to "Derating"), 5,000m (16,500feet) max STORAGE TEMP., HUMID. AND ALTITUDE -20 to +75°C, 20 - 90%RH (Non condensing), 9,000m (30,000feet) max VIBRATION 10 - 55Hz 19.6m/s ² (2G), 3minutes period, 60minutes each along X, Y and Z axis IMPACT 196.1m/s ² (20G), 11ms, once each X, Y and Z axis				
SAFETY AND NOISE REGULATIONS	AGENCY APPROVALS UL62368-1, C-UL (equivalent to CAN/CSA-C22.2 No.62368-1), EN62368-1, Complies with DEN-AN CONDUCTED NOISE *7 Complies with CISPR11-B, CISPR32-B, EN55011-B, EN55032-B, FCC Part 15-B, FCC Part 18-B, VCCI-B HARMONIC ATTENUATOR *8 Complies with IEC61000-3-2 (Class A) (No built-in power factor correction)				
OTHERS	CASE SIZE/WEIGHT 25.4 X 27.5 X 58.5mm [1.00 X 1.08 X 2.30 inches] (W X H X D) / 70g max (with cover : 90g max) COOLING METHOD *2 Convection/Forced air (Requires external fan) (Refer to "Derating")				

*1 The listed options may affect the published standard specifications. Please contact us for detailed product specifications.
 *2 Derating is required. () means peak current. There is a possibility that an internal device is damaged when the specification is exceeded. Please contact us about the detail.
 *3 At low load conditions, the burst mode operation will start. To check load regulation, you will need to measure the characteristics at average mode with instruments.
 *4 This is the value that measured on measuring board with capacitor of 22μF and 0.1μF at 50mm from output terminal.(Refer to Instruction Manual)
 *5 12V output product, the maximum temperature of 45°C.
 *6 Drift is the change in DC output for an eight hour period after a half-hour warm-up at 25°C, with the input voltage held constant at the rated input/output.
 *7 When secondary circuit will be connected to earth, the spec will be changed. (Refer to Instruction Manual 2)
 *8 Please contact us about another class. When two or more units are operating it may not comply with the IEC61000-3-2. Please contact us for details.
 * To meet the specification, do not operate overload condition.
 * Parallel operation is not possible.
 * Sound noise may be emitted from the power supply depending on operating conditions.

Block diagram

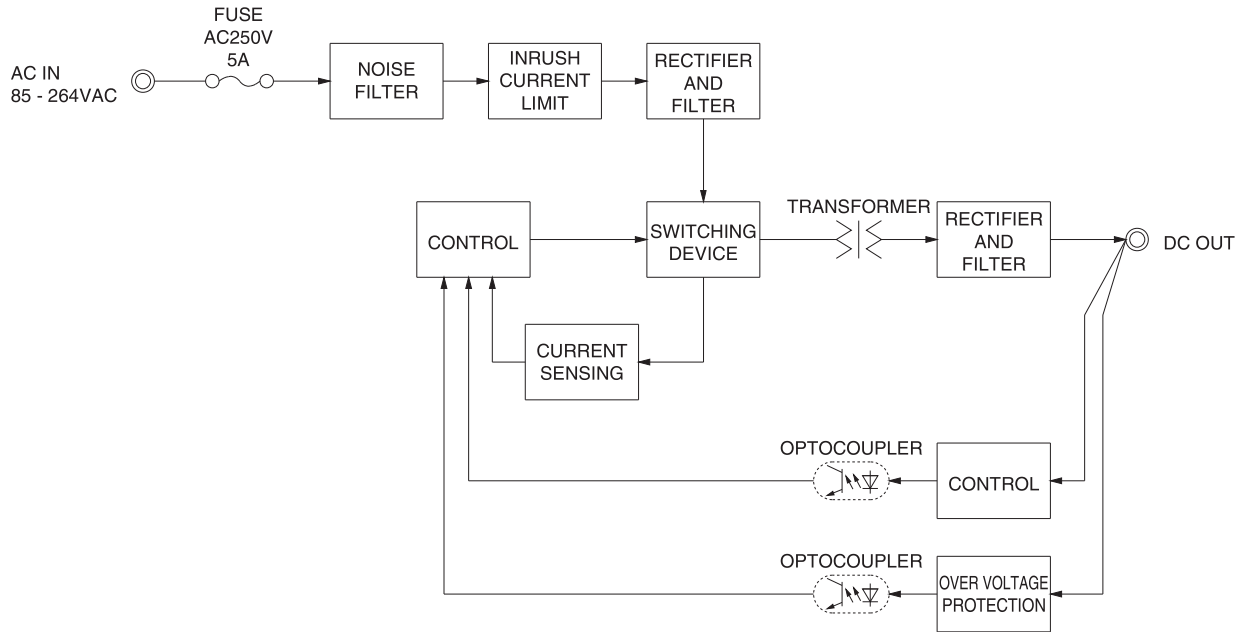

External view

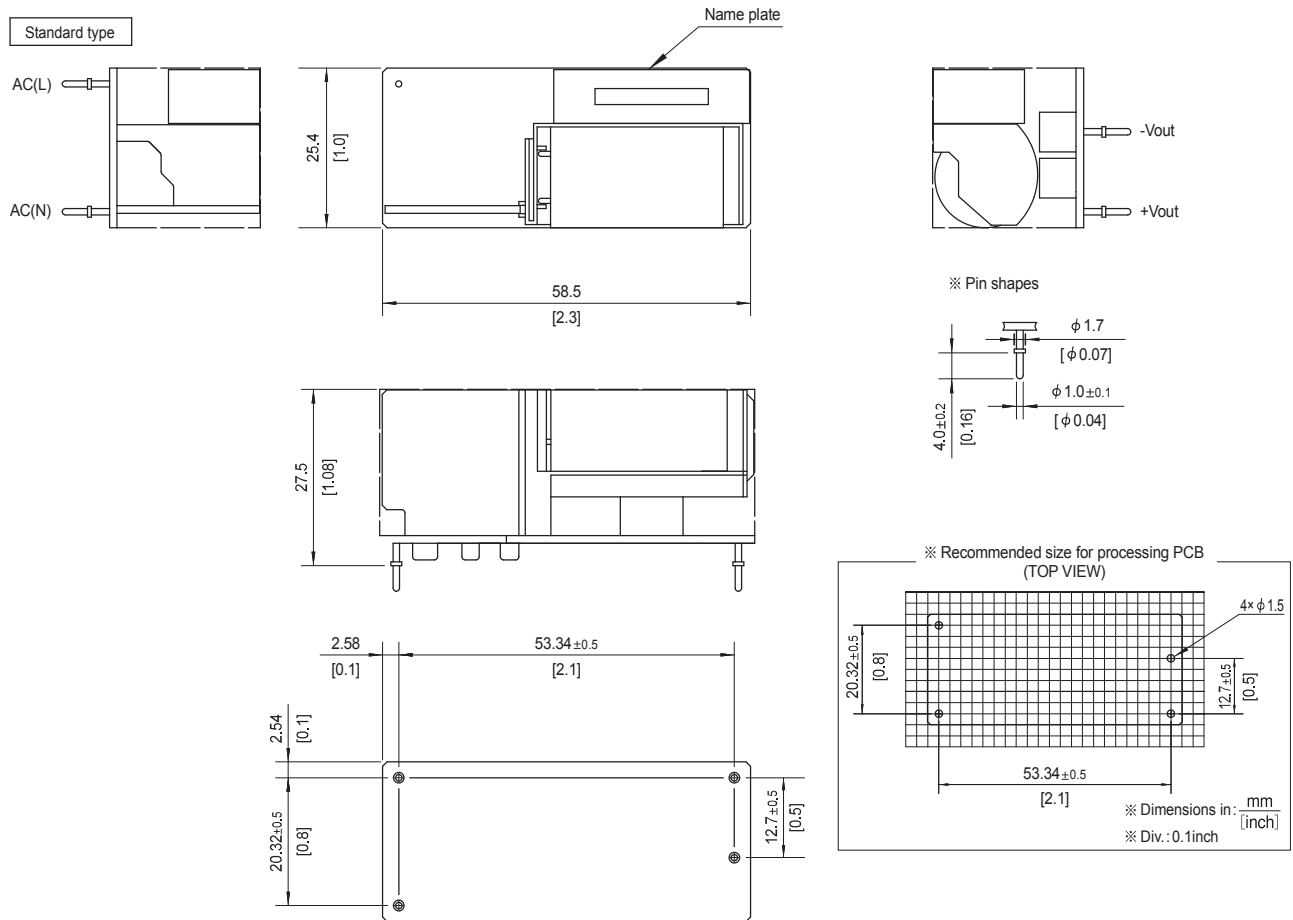

- ※ Dimensions in mm, []=inches
- ※ Tolerance : ±1.5 [±0.06]
- ※ Weight : 70g max
- ※ PCB Material / thickness : FR-4 / 1.1 [0.04]
- ※ Pin material : Copper
- ※ Plating treatment of pin : Lead free plating

External view

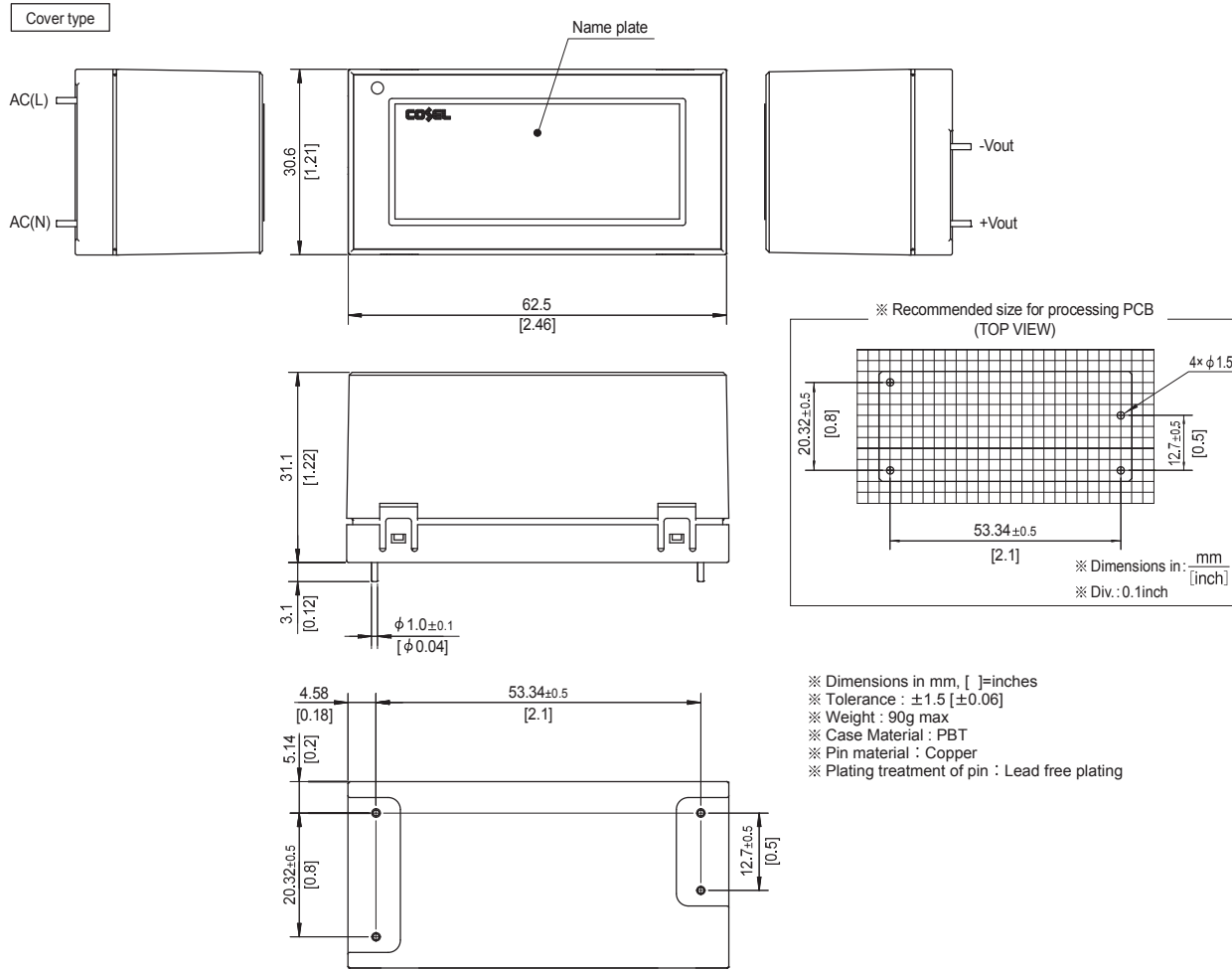

Specifications are subject to change without notice, E&OE. ALL PSU Terms & Conditions apply.
ALL PSU Ltd, Unit D6 Laser Quay, Culpeper Close, Medway City Estate,
Rochester, Kent, ME2 4HU, Tel : 01634 725527, Fax : 01634 739111
Email: sales@allpsu.co.uk, Web: www.allpsu.co.uk