



electronicpowersolutions

NC10HW Series

10W 4:1 Regulated Single & Dual output

Features

- Reinforced Insulation for 250Vrms Working Voltage
- Compact DIP-24 Package
- Wide 4:1 Input Range
- Isolation Voltage up to 5000VAC
- Over Voltage Protection
- Over Load Protection
- Continuous Short Circuit Protection
- Remote On/Off Control
- Under Voltage Protection
- Soft Start
- No minimum load required
- Efficiency up to 89%
- -40~100°C Operation Temperature Range



PART NUMBER STRUCTURE

NC 10 H W - 24 05 S
 (1) (2) (3) (4) (5) (6) (7)

(1) Series

(2) Watt

10 - 10 W

(3) High Isolation

(4) Wide Input Range

W - 4 : 1

(5) Input Voltage Range

12 - 4.5-18 V

24 - 9-36 V

48 - 18-75 V

(6) Output Voltage

05 - 5.0 V

12 - 12 V

15 - 15 V

(7) Output Type

S - Single Output

D - Dual Output

ALL SPECIFICATIONS ARE TYPICAL AT 25°C, NOMINAL INPUT AND FULL LOAD UNLESS OTHERWISE NOTED

MODEL NUMBER	INPUT Voltage Range (Vdc)	INPUT Current		OUTPUT Voltage (Vdc)	OUTPUT Current		EFFICIENCY @FL (%, typ.)	Capacitive Load @FL (µF, max.)
		No-Load (mA, typ.)	Full Load (mA, typ.)		Min. load (mA)	Full load (mA)		
NC10HW-1205S	12 (4.5-18)	20	987	5	0	2000	84.5	3300
NC10HW-1212S	12 (4.5-18)	20	964	12	0	833	86.5	470
NC10HW-1215S	12 (4.5-18)	20	947	15	0	666	88	390
NC10HW-1205D	12 (4.5-18)	20	987	±5	0	±1000	84.5	±1470
NC10HW-1212D	12 (4.5-18)	20	962	±12	0	±416	86.5	±680
NC10HW-1215D	12 (4.5-18)	20	947	±15	0	±333	88	±390
NC10HW-2405S	24 (9-36)	6	488	5	0	2000	85.5	3300
NC10HW-2412S	24 (9-36)	6	474	12	0	833	88	470
NC10HW-2415S	24 (9-36)	6	468	15	0	666	89	390
NC10HW-2405D	24 (9-36)	6	488	±5	0	±1000	85.5	±1470
NC10HW-2412D	24 (9-36)	6	473	±12	0	±416	88	±680
NC10HW-2415D	24 (9-36)	6	468	±15	0	±333	89	±390
NC10HW-4805S	48 (18-75)	4	244	5	0	2000	85.5	3300
NC10HW-4812S	48 (18-75)	4	237	12	0	833	88	470
NC10HW-4815S	48 (18-75)	4	237	15	0	666	88	390
NC10HW-4805D	48 (18-75)	4	244	±5	0	±1000	85.5	±1470
NC10HW-4812D	48 (18-75)	4	237	±12	0	±416	88	±680
NC10HW-4815D	48 (18-75)	4	237	±15	0	±333	88	±390

INPUT SPECIFICATIONS					
Parameter	Conditions	Min.	Typ.	Max.	Unit
Input Voltage Range	12V Input	4.5	12	18	VDC
	24V Input	9	24	36	
	48V Input	18	48	75	
Under Voltage Protection	12V Input	Module ON		4.2	VDC
		Module OFF		3.5	
	24V Input	Module ON		8.6	
		Module OFF		7	
	48V Input	Module ON		17.8	
		Module OFF		16	
Input Filter		Pi Type			
Input Reflected Ripple Current (1)			20		mApk-pk
Start up Time	Nominal Vin and constant resistive load		30		ms
Remote ON/OFF Control (2)	Module ON (Open Circuit)	0		1.2	VDC
	Module OFF	2.2		12	
	OFF Idle Current		2.5		mA
	CTRL Pin Input Current	-0.5		1.0	
Recommended input fuse (slow blow)	12V Input	5			A
	24V Input	2			
	48V Input	1			
Note : 1. Measured with a simulated source inductance of 12μH and a source capacitor Cin (47μF, ESR<1.0Ω at 100kHz). 2. The remote on/off control pin is referenced to -Vin (pin2).					

ABSOLUTE MAXIMUM RATINGS					
Parameter	Conditions	Min.	Typ.	Max.	Unit
Input Surge Voltage (100 ms)	12V Input			25	VDC
	24V Input			50	
	48V Input			100	
Soldering Temperature	1.5mm from case 10sec max.			260	°C
Note : These are stress ratings. Exposure of devices to any of these conditions may adversely affect long-term reliability.					

OUTPUT SPECIFICATIONS						
Parameter	Conditions	Min.	Typ.	Max.	Unit	
Output Voltage Accuracy		-1		+1	%	
Output Voltage Adjustability (Trim)		-10		+10	%	
Line Regulation		-0.5		+0.5	%	
Load Regulation	From 0% to 100% Load	Single Output	-0.5		+0.5	%
		Dual Output	-1		+1	
Cross Regulation	Asymmetrical Load 25% / 100% for Dual Output	-5		+5	%	
Ripple & Noise (1)	20MHz bandwidth	5V Output		30	mVpk-pk	
		12V & 15V Output		40		
Over Voltage Protection (Zener diode clamp)	5V Output		6.2		VDC	
	12V Output		15			
	15V Output		18			
Over Current Protection			160		% of FL	
Short Circuit Protection		Indefinite (hiccup) (Automatic Recovery)				
Temperature Coefficient		-0.02		+0.02	%/°C	
Capacitive Load	Minimum Vin and constant resistive load	See Table				
Transient Recovery Time	Nominal Vin and 25% load step change (75%-50%-25% of Io)	All models		250	µs	
Transient Response Deviation		5V Output	-5		+5	%
		12V & 15V Output	-3		+3	
Note :						
1. Measured with a 10µF ceramic capacitor.						

GENERAL SPECIFICATIONS					
Parameter	Conditions	Min.	Typ.	Max.	Unit
Isolation Voltage	Input-output, and rated for 60sec	5000			VAC
Isolation Resistance	Input-output	1			GΩ
Isolation Capacitance	Input-output		17		pF
Leakage Current	240VAC, 60Hz		2.0		µA
Clearance/Creepage		8			mm
Switching Frequency			300		kHz
MTBF	MIL-HDBK-217 F @ 25°C	650			k hours
Safety Standard	IEC / EN / UL 62368-1	DK-133116-UL, E252573			
Insulation System		Reinforced Insulation			
Environmental compliance		RoHS			

ENVIRONMENT SPECIFICATIONS					
Parameter	Conditions	Min.	Typ.	Max.	Unit
Operating Temperature	See the Derating Curve	-40		100	°C
Maximum Case Temperature				105	°C
Thermal Impedance		18			°C/W
Storage Humidity				95	% rel. H
Storage Temperature		-55		125	°C
Cooling	Natural Convection	30-65 LFM			

EMC SPECIFICATIONS			
Parameter	Standard	Condition	Criterion
Conducted Emissions	EN55032	without external components	A
Radiated Emissions	EN55032	without external components	A
ESD	IEC 61000-4-2	Air ± 15kV, Contact ± 8kV	A
RS	IEC 61000-4-3	10V/m	A
EFT	IEC 61000-4-4	±2kV with external components	A
Surge	IEC 61000-4-5	±2kV with external components	A
CS	IEC 61000-4-6	10Vrms	A
PFMF	IEC 61000-4-8	100A/m	A

PHYSICAL SPECIFICATIONS	
Parameter	Value
Case Material	Non-conductive Black Plastic (UL94V-0 rated)
Base Material	Non-conductive Black Plastic (UL94V-0 rated)
Pin Material	Ø0.5mm Brass Solder-coated
Potting Material	Silicone (UL94V-0 rated)
Weight	14.0 g, typ.
Dimensions	1.25" x 0.80" x 0.41"

ELECTRICAL CHARACTERISTIC CURVES

NC10HW-1205S \ NC10HW-1205D

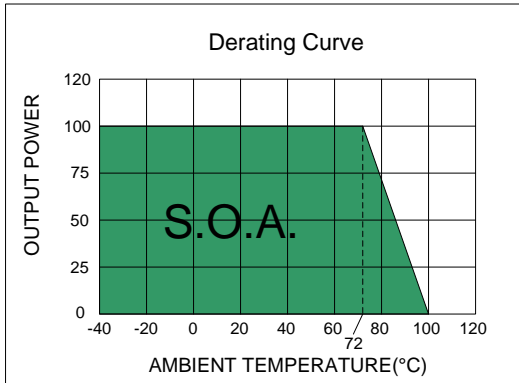

NC10HW-2405S \ NC10HW-2405D
NC10HW-4805S \ NC10HW-4805D

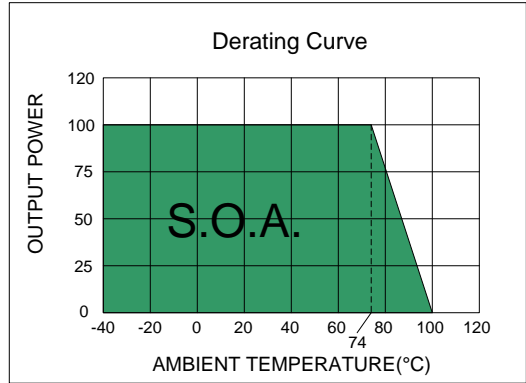

NC10HW-1212S \ NC10HW-1212D

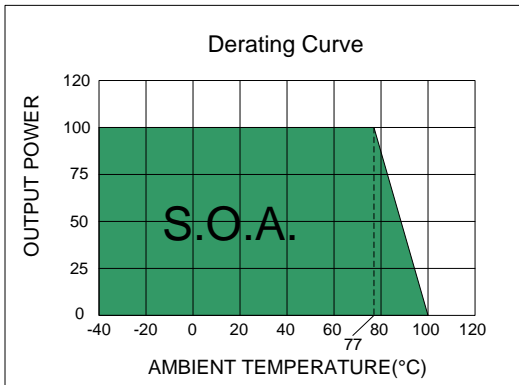

NC10HW-1215S \ NC10HW-1215D \ NC10HW-2412S \ NC10HW-2412D
NC10HW-4812S \ NC10HW-4812D \ NC10HW-4815S \ NC10HW-4815D

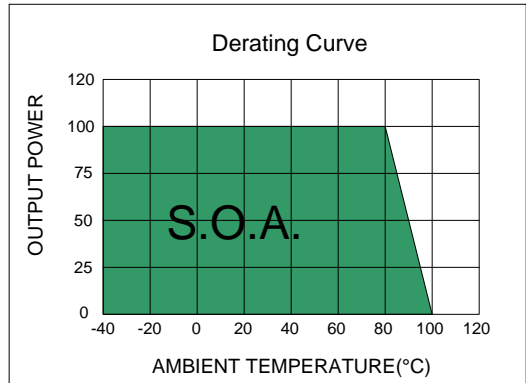

NC10HW-2415S \ NC10HW-2415D

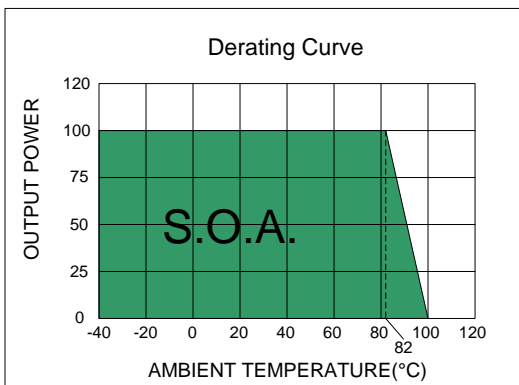

TEST CONFIGURATIONS

Input Reflected Ripple Current Test Step

Input reflected ripple current is measured with a source inductor L_{in} ($12\mu\text{H}$) and a source capacitor C_{in} ($47\mu\text{F}$, $\text{ESR} < 1.0\Omega$ at 100KHz) at nominal input and full load.

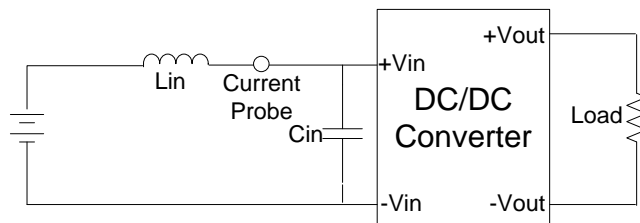

DESIGN & FEATURE CONFIGURATIONS

Over Current Protection

The module includes an internal over current protection circuit, which will endure current limiting for an unlimited duration during output over load condition. If the output current exceeds the OCP set point, the module will shut down automatically (hiccup). The module will try to restart after shut down. If the over load condition still exists, the module will shut down again.

Over Voltage Protection

The module includes an internal output over voltage protection circuit, which monitors the voltage on the output terminals. If this voltage exceeds the over voltage set point, the module will activate the control loop of internal circuit to clamp the output voltage.

Remote Module ON / OFF

Negative logic turns on the module during low logic and off during high logic. For negative logic if the Remote feature is not used, please leave the Remote pin floating or connected -Vin.

EMC Filter

The Circuit is used to meet Surge & EFT test.

Single

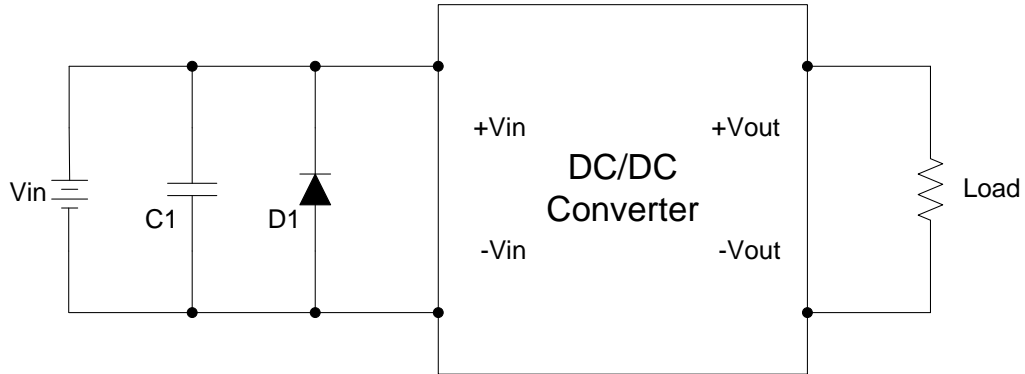

Dual

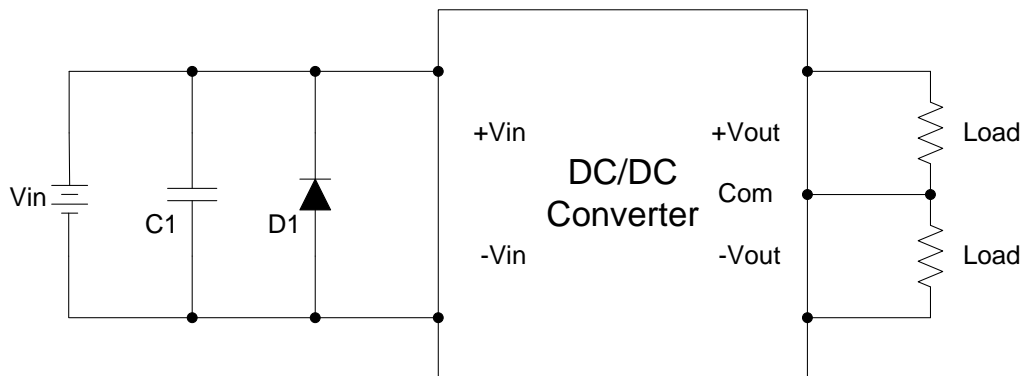

	C1	D1
NC10HW-12XXO	NIPPON chemi-con KY series 470 μ F, 100V	Littelfuse SMDJ26A
NC10HW-24XXO	NIPPON chemi-con KY series 330 μ F, 100V	Littelfuse SMDJ58A
NC10HW-48XXO	NIPPON chemi-con KY series 330 μ F, 100V	Littelfuse SMDJ120A

MECHANICAL SPECIFICATIONS

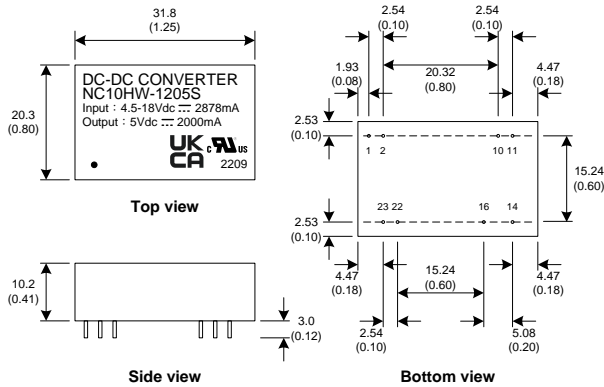

Notes : All dimensions are typical in millimeters (inches).

1. Pin diameter: 0.5 ± 0.05 (0.02 ± 0.002)
2. Pin pitch and length tolerance: ± 0.35 (± 0.014)
3. Case tolerance: ± 0.5 (± 0.02)

PIN CONNECTIONS

PIN NUMBER	SINGLE	DUAL
1	CTRL	CTRL
2	-Vin	-Vin
10	Trim	Trim
11	N.C.	-Vout
14	+Vout	+Vout
16	-Vout	COM
22	+Vin	+Vin
23	+Vin	+Vin

PIN CONNECTIONS

Output can be externally trimmed by using the method as below.

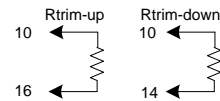

Single Output Models

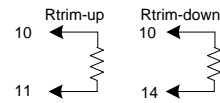

Dual Output Models

RECOMMEND FOOTPRINT DETAILS

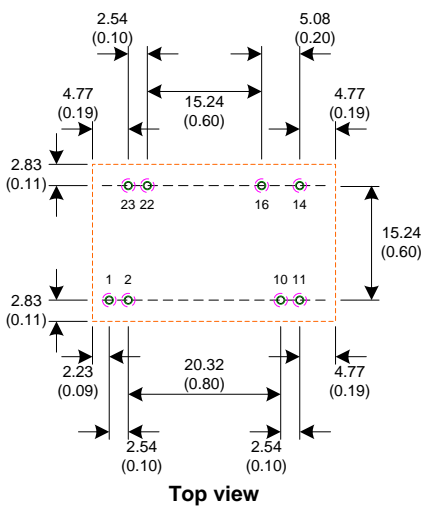

Notes : 1. All dimensions are typical in millimeters (inches).

Through hole(Black) 2, 3, 10, 11, 14, 16, 22, 23 : $\varnothing 0.90$ (0.035)

Top view pad(Green) 2, 3, 10, 11, 14, 16, 22, 23 : $\varnothing 1.10$ (0.044)

Bottom view pad(Pink) 2, 3, 10, 11, 14, 16, 22, 23 : $\varnothing 1.80$ (0.071)

2. There should be at least 8mm distance between primary and secondary circuit.