

KEY FEATURES

- Universal Input 90-264Vac
- High Efficiency up to 93%
- Operating Altitude 5000M
- Over-Voltage Category OVC III
- Standby 5V@1A with Fan
- Active PFC Function
- I/O Isolation 4250VAC
- Safety Approval to UL / IEC / EN 62368-1
- 3-Year Product Warranty

ELECTRICAL SPECIFICATIONS

All specifications valid at normal input voltage, full load and +25°C after warm-up time unless otherwise stated.

Model No.		ARF1300F-12S	ARF1300F-24S	ARF1300F-48S	
Max Output Wattage (W) (Note 5)		1000 W (115 VAC) / 1100 W (230 VAC)	1300 W		
Input	Voltage (Note 5)	90-264 VAC			
	Frequency (Hz)	47-63 Hz			
	Current (Full load)	< 14 A max. (115 VAC) / < 7 A max. (230 VAC)			
	Inrush Current (<2ms) (Clod Start)	< 70 A max. (115 VAC) / < 105 A max. (230 VAC)			
	Leakage Current	< 1.5mA / 264 VAC (Touch Current)			
	Power Factor (at 230 VAC)	PF>0.9 at Full Load			
Output	Voltage (V.DC.)	12V	24V	48V	
	Voltage Adj Range (V.DC.)	±5% Output Voltage			
	Voltage Accuracy	±2%			
	Current (A) (max.)	at 115 VAC	83.4	54.1	27.1
		at 230 VAC	91.6	54.1	27.1
	Line Regulation (100-264 VAC)	±1%			
	Load Regulation (10-100%) (typ.)	±1%			
	Maximum Capacitive Load	7,000µF	3,500µF	1,750µF	
	Ripple & Noise (10-100%) (typ.) (Note 1)	160mV	1% Vout		
	Efficiency (at 230VAC)	90.5%	92.5%	93%	
Hold-up Time (at 115 VAC) (Note 2)	3ms min.				
Protection	Over Power Protection	Auto recovery			
	Over Voltage Protection	Auto recovery			
	Overt Temperature Protection	Auto recovery			
	Short Circuit Protection	Protection level 1 (nominal) : Continuous, Auto recovery			
Protection level 2 (instantaneous high current) : Latch					
Isolation	Input-Output (Note 3)	4250VAC or 6000VDC			
	Input-PE (Note 3)	2850VAC or 4000VDC			
	Output-PE (Note 3)	1500VAC or 2121VDC			
Function	5V Stand by	5VSB: 5V@1A with FAN ; Tolerance ±10%			
	DC OK Signal (Power Good)	Turn ON: 3.7~5.7V ; Turn OFF: 0~1V			
	Remote Control	+RC / -RC: Power ON=open ; Power OFF=short			

ELECTRICAL SPECIFICATIONS

All specifications valid at normal input voltage, full load and +25°C after warm-up time unless otherwise stated.

Model No.	ARF1300F-12S	ARF1300F-24S	ARF1300F-48S
Environment	Operating Temperature (Note 5,6)	-30°C...+70°C (with derating)	
	Storage Temperature	-30°C...+85°C	
	Temperature Coefficient	±0.03%/°C (0~50°C)	
		±0.06%/°C (Other)	
	Altitude During Operation	OVC II=5000m 、 OVC III=2000m	
	Humidity	95% RH	
	MTBF	>100,000 h @ 25°C (MIL-HDBK-217F)	
	Vibration	IEC60068-2-6 (10~500Hz, 2G 10min./1cycle, 60min. each along X, Y, Z axes)	
	Shock	IEC60068-2-27	
	Dimension (L x W x H)	8.84 x 4.49 x 1.62 Inches (224.5 x 114.0 x 41.0) Tolerance ±0.5 mm	
	Weight	1450 g	
Approval	UL / IEC / EN 62368-1		
EMI	Conducted (Note 4)	EN55032 Class B	
	Radiated (Note 4)	EN55032 Class B	
EMS	EN 55035		
	ESD	IEC 61000-4-2 Air ± 15KV , Contact ± 8KV	A
	RS	IEC 61000-4-3 3V/m	A
	EFT/B	IEC 61000-4-4 ± 4KV	A
	Surge	IEC 61000-4-5 ± 4KV(L/N-PE)	A
	CS	IEC 61000-4-6 3Vrms	A
	PFMF	IEC 61000-4-8 1A/m	A
	Dips	IEC 61000-4-11 70% 500ms	A
	Interruptions	IEC 61000-4-11 <5% 5000ms	B

NOTE

- Ripple & Noise are measured at 20MHz of bandwidth by using a 6" twisted pair-wire terminated with a 0.1uF & 47uF parallel capacitor.
- Hold-up Time measured at 90% Vout.
- Strongly recommend to conduct this test with DC Voltage. If customer wishes to test with AC Voltage, please disconnect all Y-Capacitors from Arch power supply.
- For optimal EMI performance the power supply should be mounted to a grounded aluminium plate (650 x 650 x 3 mm) with electrical contact to the four PCB mounting holes. To comply with safety standards, this plate must be grounded.
- Please check the derating curve for more details.
- Due to varying customer application conditions, the product is tested for maximum operating temperature under full load only. For other regulatory requirements, please contact ARCH.
- CAUTION: Double pole, neutral fusing. Disconnect mains before servicing.
(ATTENTION : 2 poles avec fusible sur le neutre. Deconnecter le secteur avant intervention.)

DERATING

Derating Output Load versus Operating Temperature
ARF1300F-12S at 115-197Vin

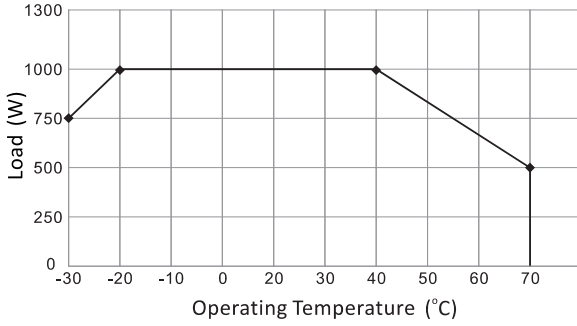

If input voltage is lower than 115VAC, please refer to the output derating V.S. input voltage curve for details

Derating Output Load versus Operating Temperature
ARF1300F-12S at 198-264Vin

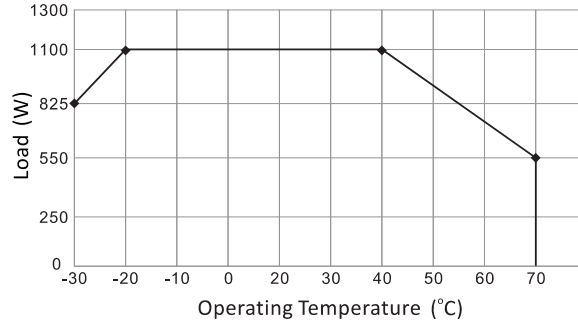

Derating Output Load versus Operating Temperature
ARF1300F-24S,48S

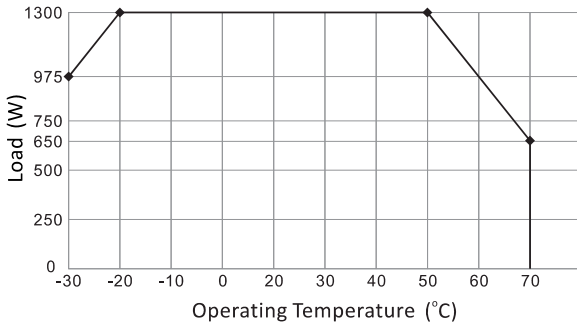

If input voltage is lower than 115VAC, please refer to the output derating V.S. input voltage curve for details

Derating Load versus Input Voltage

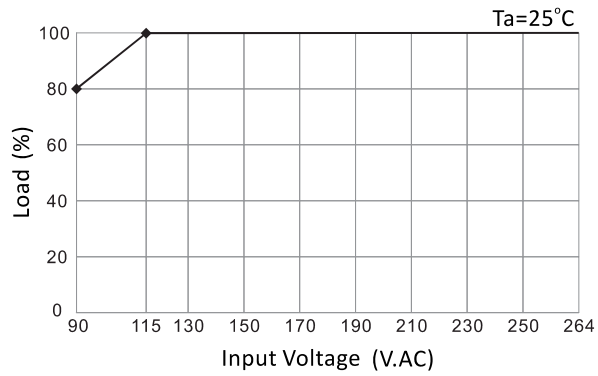

MECHANICAL DIMENSIONS (External View)

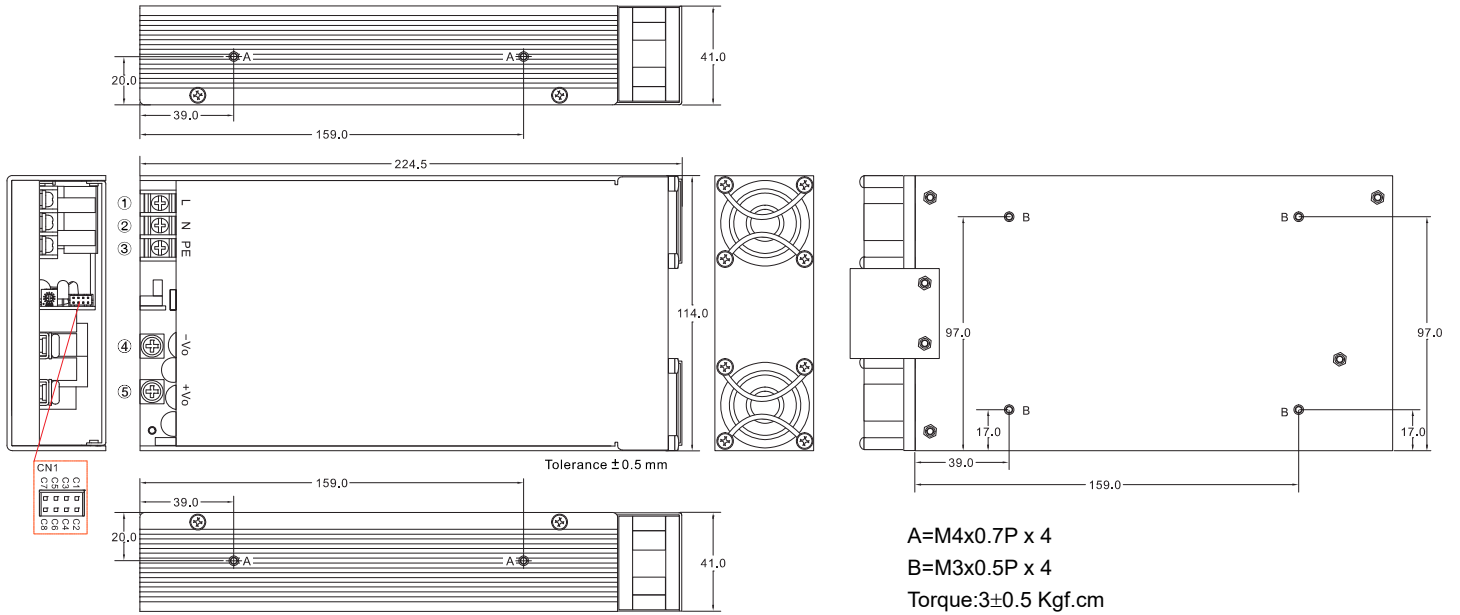

ASSEMBLY INSTRUCTIONS

*U Case T=2.5mm
 Customer is advised to screw into the threads no more than 2.5mm

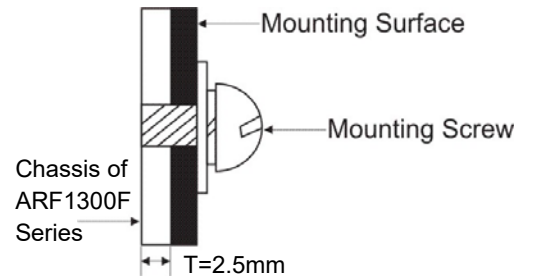

Brands		
PIN#	Single	Terminal
1	AC IN (L)	DINKLE DT-49-B01W-03
2	AC IN (N)	
3,A,B	PE	
4	-DC OUT	M5 Pan HD screw in 2 positions Torque to 8 lbs-in(90 cNm) max.
5	+DC OUT	

Connector Pin (CN1)					
Brands		Cherng Weei		JST	
PIN#	Single	Mating Housing	Terminal	Mating Housing	Terminal
C1	+S	PHD-H20-2X4P	PHD-T20	PHDR-08VS	SPHD-001T-P0.5
C2	-S				
C3	NC				
C4	-5V SB				
C5	GND / -RC				
C6	+RC				
C7	PG				
C8	+5V SB				

FUNCTION DESCRIPTION of CN1

Pin No.	Function	Description
C1	+S	Remote sensing (+)
C2	-S	Remote sensing (-)
C3	NC	
C4	-5V SB	This pin connects to the negative terminal(-V)
C5	GND / -RC	This pin connects to the negative terminal(-V). Return for DC-OK signal output.
C6	+RC	Turns the output on and off by electrical or dry contact between pin C5 (GND / -RC), Short: Power OFF, Open: Power ON.
C7	+PG	DC-OK Signal is a DC output. (DC-OK)
C8	+5V SB	Stand by voltage output ground 4.4~5.5V, referenced to pin C4 or C5(GND). The maximum load current is 1A.

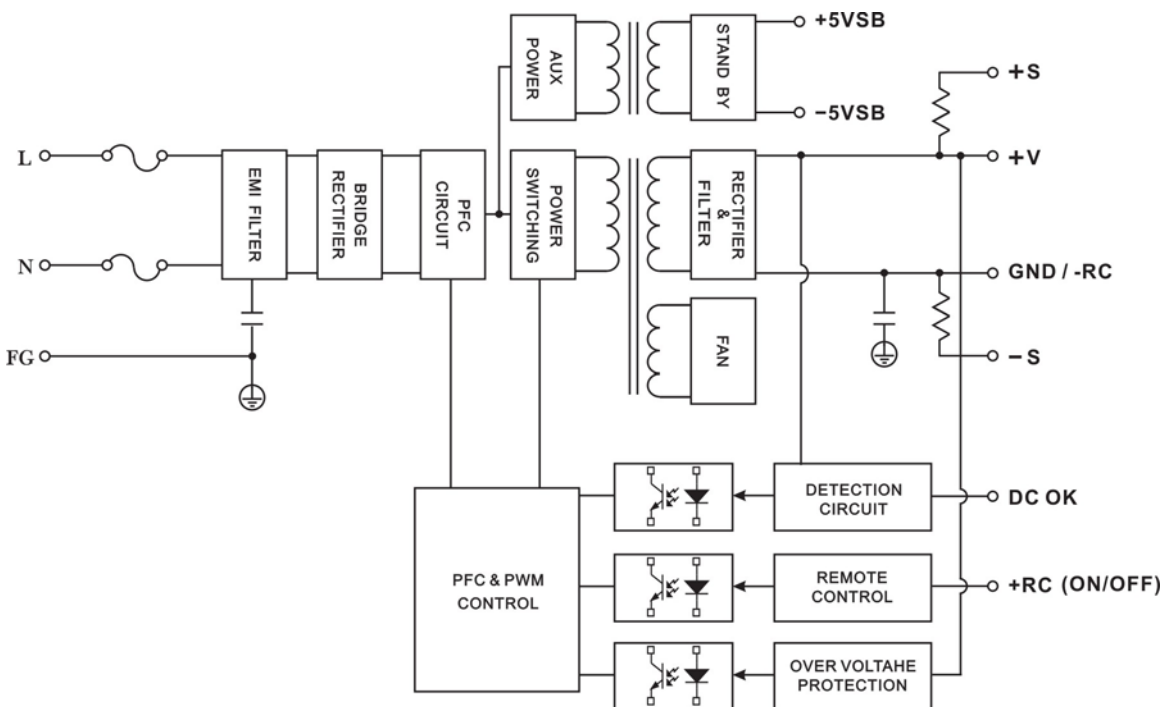
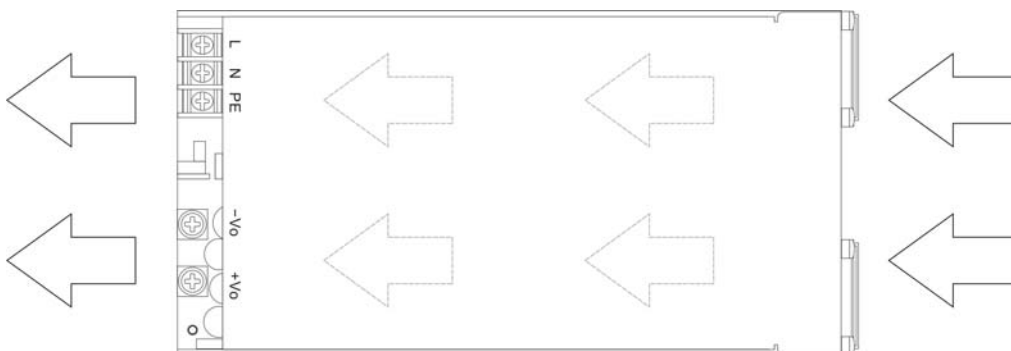
BLOCK DIAGRAM

AIR FLOW DIRECTION

Specifications are subject to change without notice, E&OE. ALL PSU Terms & Conditions apply.

ALL PSU Ltd, Unit D6 Laser Quay, Culpeper Close, Medway City Estate,
Rochester, Kent, ME2 4HU, Tel : 01634 725527, Fax : 01634 739111
Email: sales@allpsu.co.uk, Web: www.allpsu.co.uk